



**APEX DYNAMICS, INC.**

**AT-L >**



**AT-FL >**



**AT-H >**



**AT-FH >**



**AT-C >**



# **AT SERIES**

*High Precision Spiral  
Bevel Gearboxes*

**AT-FC >**

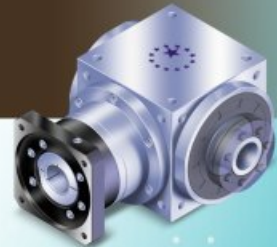

**AT-4M >**



**Stainless**

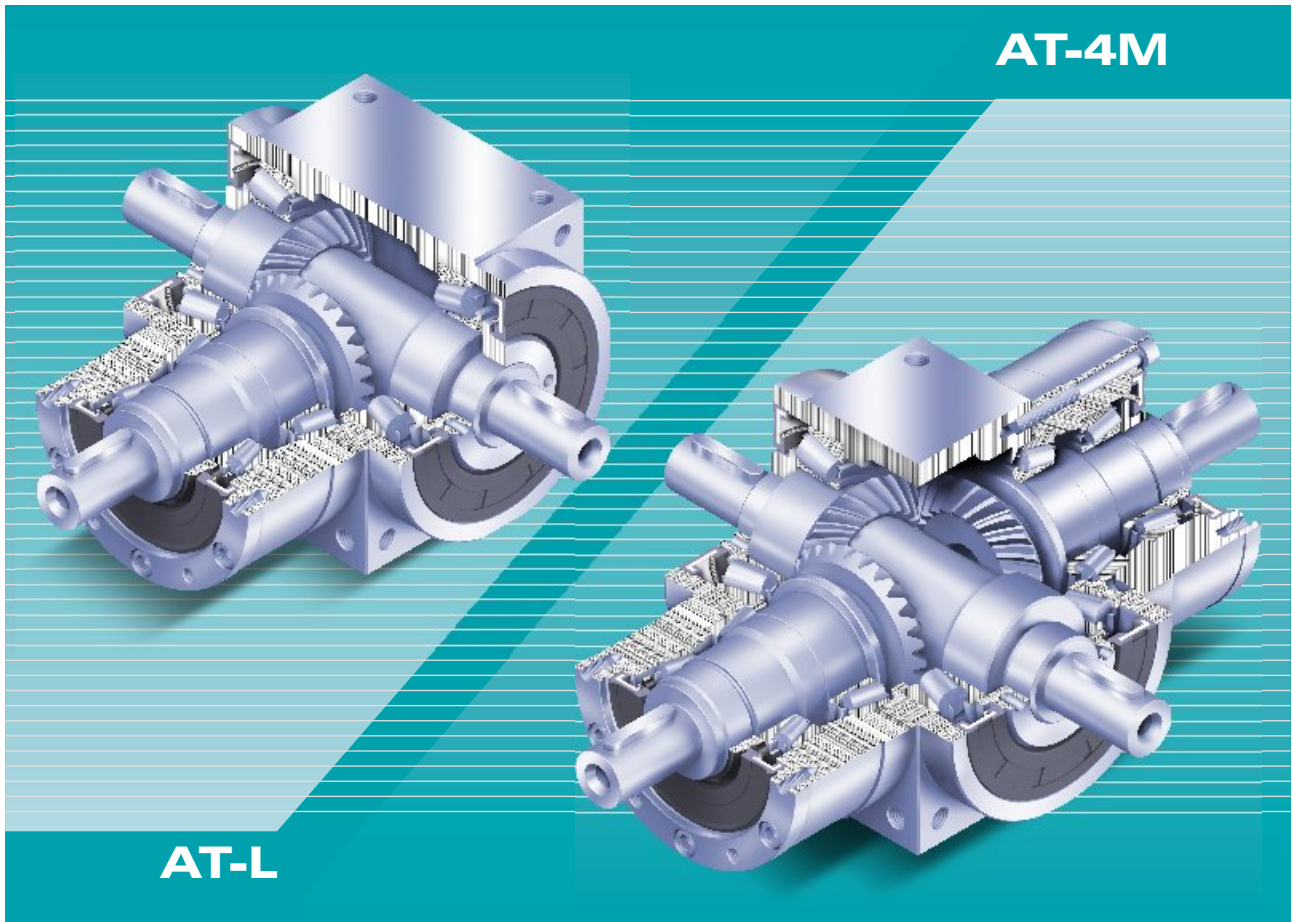

- ▶ 一體化不鏽鋼本體確保最大剛性與耐蝕性，多重精密加工表面易於組裝。
- ▶ 採用頂級蜗線傘齒輪的設計軟體，經最佳化設計接觸齒面負載均一容許高扭矩輸出，齒輪採高強力滲碳合金鋼，研磨精密度符合 DIN 5 級標準以內。
- ▶ 多重不鏽鋼輸出入力軸的設計可以適用於各種工業上應用的需求。
- ▶ 高精密研磨的蜗線傘齒輪組結合最佳化設計的行星式齒輪組可以達到 500:1 的減速比。
- ▶ 高扭矩低背隙的精簡結構設計適用於精密伺服的應用。
- ▶ 專利的油封設計，免保養無需更換潤滑油，運轉壽命長。

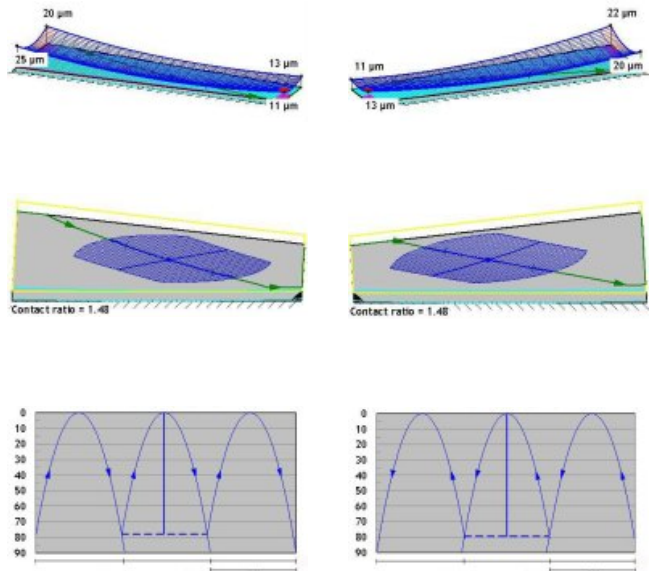

# AT 軸型系列

## 產品規格



### 減速機性能資料

規 格		節 數	比 數	AT065 L	AT075 L	AT090 L	AT110 L	AT140 L	AT170 L	AT210 L	AT240 L	AT280 L	
				AT065 L1	AT075 L1	AT090 L1	AT110 L1	AT140 L1	AT170 L1	AT210 L1	AT240 L1	AT280 L1	
額定輸出力矩 $T_{2N}$		Nm	1	1	25	45	78	150	360	585	1,300	2,150	3,200
				1.5	25	45	78	150	360	585	1,300	2,150	3,200
				2	24	42	68	150	330	544	1,220	2,010	3,050
				3	18	33	54	120	270	450	1,020	1,650	2,850
				4	13	28	48	100	224	376	860	1,410	2,300
最大加速力矩 $T_{2B}$		Nm	1	1.5 倍額定輸出力矩									
				1.5 倍額定輸出力矩									
				1.5 倍額定輸出力矩									
				1.5 倍額定輸出力矩									
				1.5 倍額定輸出力矩									
最大加速輸入轉速 $n_{1B}$		rpm	1	1~5	7,500	6,500	5,500	4,500	3,500	3,000	2,200	2,000	1,700
背隙*		arcmin	1	1~5	≤6	≤6	≤6	≤6	≤6	≤6	≤6	≤6	≤6
容許徑向力 $F_{1B}$ <sup>2</sup> 輸入軸 d1		N	1	1~5	700	950	1,450	2,100	2,700	3,800	7,800	9,600	10,500
容許徑向力 $F_{2B}$ <sup>3</sup> 輸出軸 d2		N	1	1~5	900	1,100	1,700	2,700	4,800	6,600	11,500	16,000	18,000
容許軸向力 $F_{1aB}$ <sup>2</sup> 輸入軸 d1		N	1	1~5	350	425	725	1,050	1,350	1,900	3,900	4,800	5,250
容許軸向力 $F_{2aB}$ <sup>3</sup> 輸出軸 d2		N	1	1~5	450	550	850	1,350	2,400	3,300	5,750	8,500	9,000
使用壽命		hr	1	1~5	20,000*								
效率 $\eta$		%	1	1~5	≥98%								
使用溫度		°C	1	1~5	-10°C ~ 90°C								
潤滑					合成潤滑油脂								
噪音值 ( $n_1=1500\text{rpm}$ , 無負載)		dB (A)	1	1~5	≤68	≤70	≤74	≤76	≤77	≤78	≤80	≤82	≤83

1. 減速比 ( $i=N_n/N_{out}$ )

2. 作用於輸入軸中心位置 @  $n_{1B}$

3. 作用於輸出軸中心位置 @  $n_{1B}$

\* 連續運轉降低使用壽命二分之一。

\* 背隙值為在 2% 額定力矩  $T_{2N}$  的扭力下所測得

★ AT-LM / RM / 4M 只提供 1 : 1 比數

### 減速機轉動慣量

規 格		節 數	比 數	AT065 L	AT075 L	AT090 L	AT110 L	AT140 L	AT170 L	AT210 L	AT240 L	AT280 L	
				AT065 L1	AT075 L1	AT090 L1	AT110 L1	AT140 L1	AT170 L1	AT210 L1	AT240 L1	AT280 L1	
轉動慣量 $J_1$		kg · cm <sup>2</sup>	1	1	0.51	1.30	3.16	7.70	23.57	58.99	195.40	369.34	799.12
				1.5	0.64	1.16	2.82	6.74	19.37	49.28	155.45	283.58	595.78
				2	0.44	1.11	2.70	6.31	17.75	45.35	140.24	249.74	511.76
				3	0.43	1.09	2.66	6.17	17.18	44.01	134.95	237.71	483.06
				4	0.43	1.09	2.65	6.13	17.06	43.70	133.58	234.72	476.26
				5	0.43	1.09	2.65	6.12	17.02	43.60	133.14	233.67	473.58

### 重量

減 速 機 型 號	節 數	比 數	AT065	AT075	AT090	AT110	AT140	AT170	AT210	AT240	AT280
L 系列	kg	1	2.6	4.2	6.8	11.6	19.8	34.8	66.2	98.1	155.7
L1 系列		1	2.6	4.1	6.7	11.5	19.5	34.2	65.1	96.6	153.4
H 系列		1	2.5	3.9	6.4	11.0	18.1	31.6	60.0	89.4	143.4
C 系列		1	2.8	4.2	6.9	11.4	19.6	33.7	63.3	97.9	149.1
R1 系列		1	2.6	4.1	6.7	11.5	19.5	34.2	65.1	96.6	153.4
LM 系列		1	3.5	5.6	9.0	15.2	24.1	42.4	81.4	122.0	190.9
RM 系列		1	3.5	5.6	9.0	15.2	24.1	42.4	81.4	122.0	190.9
4M 系列		1	3.5	5.6	9.1	15.4	24.8	42.6	82.5	123.5	193.3

# AT-L 系列

## 尺寸 (單節, 減速比 i=1~5)

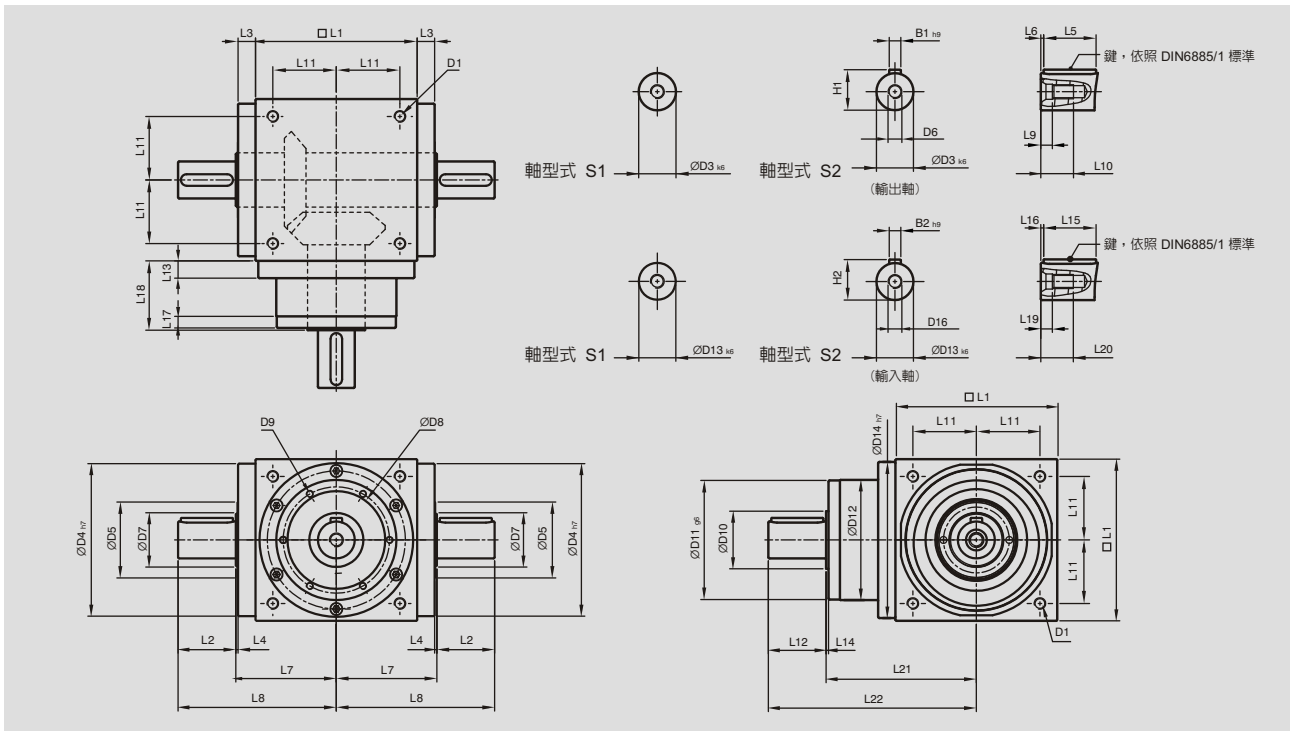

(單位: mm)

尺寸	AT065 L	AT075 L	AT090 L	AT110 L	AT140 L	AT170 L	AT210 L	AT240 L	AT280 L
D1	M4	M6	M6	M8	M10	M12	M16	M16	M16
D3 <sub>k6</sub>	13	16	18	22	32	40	50	55	60
D4 <sub>h7</sub>	63	73	88	108	135	165	205	235	275
D5	31	35	43	53	68	83	104	124	144
D6	M4	M5	M5	M8	M12	M16	M16	M16	M20
D7	21	22	28	33	47	55	75	85	110
D8	53	62	76	95	92	114	142	160	176
D9	4xM4xL7	4xM5xL8	4xM5xL8	6xM6xL10	6xM6xL10	6xM8xL12.5	6xM8xL12.5	6xM8xL12.5	6xM10xL15
D10	15.4	20.4	25.8	35.8	49.8	59.3	79.3	92.3	102.3
D11 <sub>g6</sub>	62.9	72.9	87	107	103	127	158	178	198
D12	62	72	86	106	104	128	160	180	200
D13 <sub>k6</sub>	13	16	18	22	32	40	50	55	60
D14 <sub>h7</sub>	63	73	88	108	135	165	205	235	275
D16	M4	M5	M5	M8	M12	M16	M16	M16	M20
L1	65	75	90	110	140	170	210	240	280
L2	19.5	30	35	40	50	60	75	85	110
L3	13	14.5	15	15	15	15	20	25	25
L4	2	2	2	2	2	2	2	2	2
L5	16	25	28	32	45	50	70	80	100
L6	2	2.5	3.5	4	2.5	5	2.5	2.5	5
L7	47.5	54	62	72	87	102	127	147	167
L8	67	84	97	112	137	162	202	232	277
L9	4.5	4.8	4.8	7.2	10	12	12	12	15
L10	10	12.5	12.5	19	28	36	36	36	42
L11	27	30	36	44	55	67	85	95	110
L12	19.5	30	35	40	50	60	75	85	110
L13	13	15	15	15	15	15	20	25	25
L14	2	2	2	2	2	2	2	2	2
L15	16	25	28	32	45	50	70	80	100
L16	2	2.5	3.5	4	2.5	5	2.5	2.5	5
L17	6	8	8	8	10	10	10	10	10
L18	43	52.5	55	60	60	70	90	105	120
L19	4.5	4.8	4.8	7.2	10	12	12	12	15
L20	10	12.5	12.5	19	28	36	36	36	42
L21	75.5	90	100	115	130	155	195	225	260
L22	95	120	135	155	180	215	270	310	370
B1 <sub>h9</sub>	5	5	6	6	10	12	14	16	18
B2 <sub>h9</sub>	5	5	6	6	10	12	14	16	18
H1	15	18	20.5	24.5	35	43	53.5	59	64
H2	15	18	20.5	24.5	35	43	53.5	59	64

# AT-L1 / R1 系列

## 尺寸 (單節, 減速比 $i=1\sim5$ )

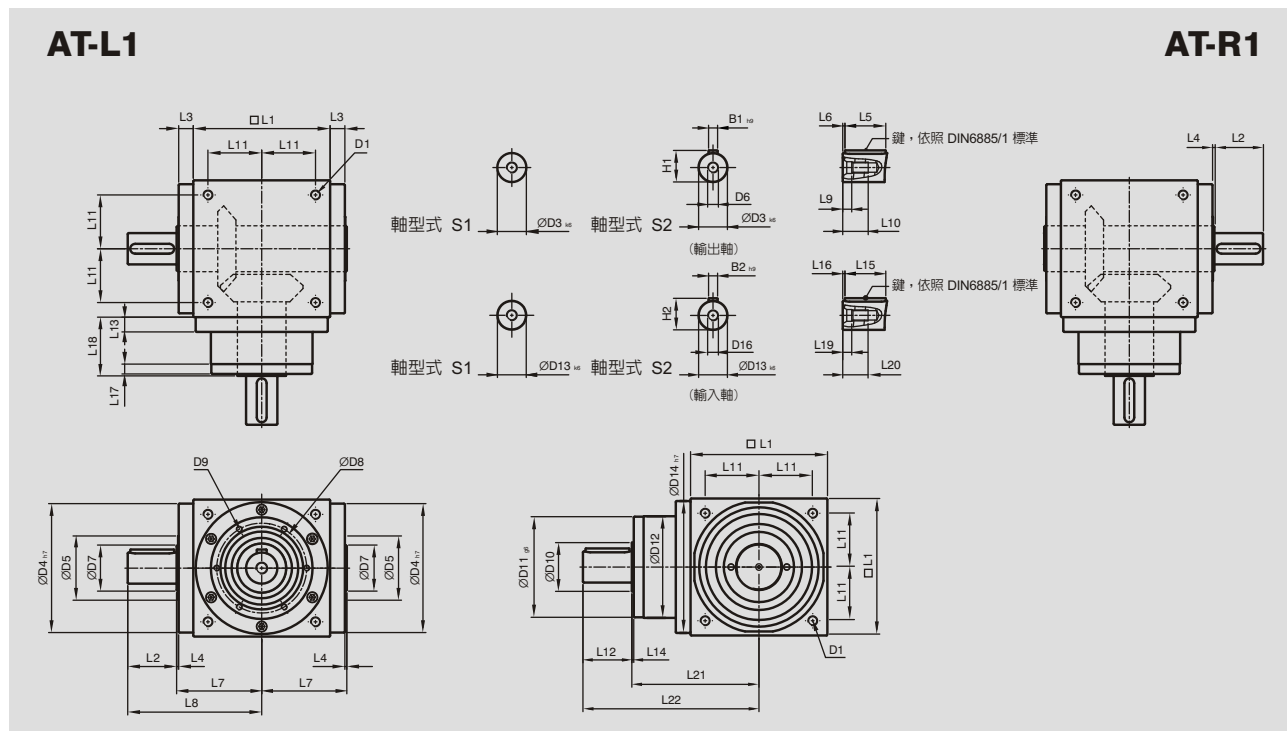

(單位: mm)

尺寸	AT065 L1/R1	AT075 L1/R1	AT090 L1/R1	AT110 L1/R1	AT140 L1/R1	AT170 L1/R1	AT210 L1/R1	AT240 L1/R1	AT280 L1/R1
D1	M4	M6	M6	M8	M10	M12	M16	M16	M16
D3 <sub>k6</sub>	13	16	18	22	32	40	50	55	60
D4 <sub>h7</sub>	63	73	88	108	135	165	205	235	275
D5	31	35	43	53	68	83	104	124	144
D6	M4	M5	M5	M8	M12	M16	M16	M16	M20
D7	21	22	28	33	47	55	75	85	110
D8	53	62	76	95	92	114	142	160	176
D9	4xM4xL7	4xM5xL8	4xM5xL8	6xM6xL10	6xM6xL10	6xM8xL12.5	6xM8xL12.5	6xM8xL12.5	6xM10xL15
D10	15.4	20.4	25.8	35.8	49.8	59.3	79.3	92.3	102.3
D11 <sub>g6</sub>	62.9	72.9	87	107	103	127	158	178	198
D12	62	72	86	106	104	128	160	180	200
D13 <sub>k6</sub>	13	16	18	22	32	40	50	55	60
D14 <sub>h7</sub>	63	73	88	108	135	165	205	235	275
D16	M4	M5	M5	M8	M12	M16	M16	M16	M20
L1	65	75	90	110	140	170	210	240	280
L2	19.5	30	35	40	50	60	75	85	110
L3	13	14.5	15	15	15	15	20	25	25
L4	2	2	2	2	2	2	2	2	2
L5	16	25	28	32	45	50	70	80	100
L6	2	2.5	3.5	4	2.5	5	2.5	2.5	5
L7	47.5	54	62	72	87	102	127	147	167
L8	67	84	97	112	137	162	202	232	277
L9	4.5	4.8	4.8	7.2	10	12	12	12	15
L10	10	12.5	12.5	19	28	36	36	36	42
L11	27	30	36	44	55	67	85	95	110
L12	19.5	30	35	40	50	60	75	85	110
L13	13	15	15	15	15	15	20	25	25
L14	2	2	2	2	2	2	2	2	2
L15	16	25	28	32	45	50	70	80	100
L16	2	2.5	3.5	4	2.5	5	2.5	2.5	5
L17	6	8	8	8	10	10	10	10	10
L18	43	52.5	55	60	60	70	90	105	120
L19	4.5	4.8	4.8	7.2	10	12	12	12	15
L20	10	12.5	12.5	19	28	36	36	36	42
L21	75.5	90	100	115	130	155	195	225	260
L22	95	120	135	155	180	215	270	310	370
B1 <sub>h9</sub>	5	5	6	6	10	12	14	16	18
B2 <sub>h9</sub>	5	5	6	6	10	12	14	16	18
H1	15	18	20.5	24.5	35	43	53.5	59	64
H2	15	18	20.5	24.5	35	43	53.5	59	64

# AT-H 系列

## 尺寸 (單節, 減速比 $i=1\sim5$ )

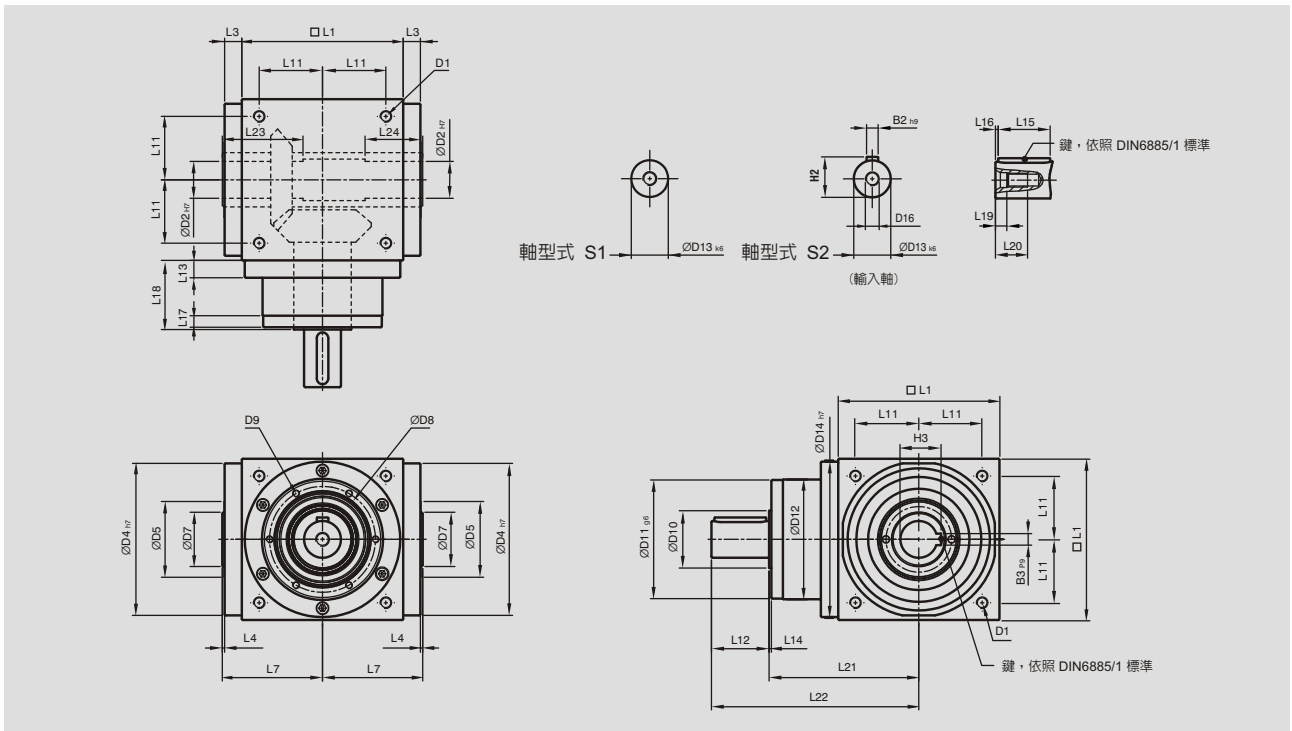

(單位: mm)

尺寸	AT065 H	AT075 H	AT090 H	AT110 H	AT140 H	AT170 H	AT210 H	AT240 H	AT280 H
D1	M4	M6	M6	M8	M10	M12	M16	M16	M16
D2 <sub>H7</sub>	13	14	18	22	32	40	50	55	60
D4 <sub>H7</sub>	63	73	88	108	135	165	205	235	275
D5	31	35	43	53	68	83	104	124	144
D7	21	22	28	33	47	55	75	85	110
D8	53	62	76	95	92	114	142	160	176
D9	4xM4xL7	4xM5xL8	4xM5xL8	6xM6xL10	6xM6xL10	6xM8xL12.5	6xM8xL12.5	6xM8xL12.5	6xM10xL15
D10	15.4	20.4	25.8	35.8	49.8	59.3	79.3	92.3	102.3
D11 <sub>g6</sub>	62.9	72.9	87	107	103	127	158	178	198
D12	62	72	86	106	104	128	160	180	200
D13 <sub>k6</sub>	13	16	18	22	32	40	50	55	60
D14 <sub>H7</sub>	63	73	88	108	135	165	205	235	275
D16	M4	M5	M5	M8	M12	M16	M16	M16	M20
L1	65	75	90	110	140	170	210	240	280
L3	13	14.5	15	15	15	15	20	25	25
L4	2	2	2	2	2	2	2	2	2
L7	47.5	54	62	72	87	102	127	147	167
L11	27	30	36	44	55	67	85	95	110
L12	19.5	30	35	40	50	60	75	85	110
L13	13	15	15	15	15	15	20	25	25
L14	2	2	2	2	2	2	2	2	2
L15	16	25	28	32	45	50	70	80	100
L16	2	2.5	3.5	4	2.5	5	2.5	2.5	5
L17	6	8	8	8	10	10	10	10	10
L18	43	52.5	55	60	60	70	90	105	120
L19	4.5	4.8	4.8	7.2	10	12	12	12	15
L20	10	12.5	12.5	19	28	36	36	36	42
L21	75.5	90	100	115	130	155	195	225	260
L22	95	120	135	155	180	215	270	310	370
L23	40	47	52	53	70	80	95	115	115
L24	30	32	35	35	50	55	65	80	80
B2 <sub>H9</sub>	5	5	6	6	10	12	14	16	18
B3 <sub>P9</sub>	5	5	6	6	10	12	14	16	18
H2	15	18	20.5	24.5	35	43	53.5	59	64
H3	15.3	16.3	20.8	24.8	35.3	43.3	53.8	59.3	64.4

# AT-C 系列

## 尺寸 (單節, 減速比 $i=1\sim5$ )

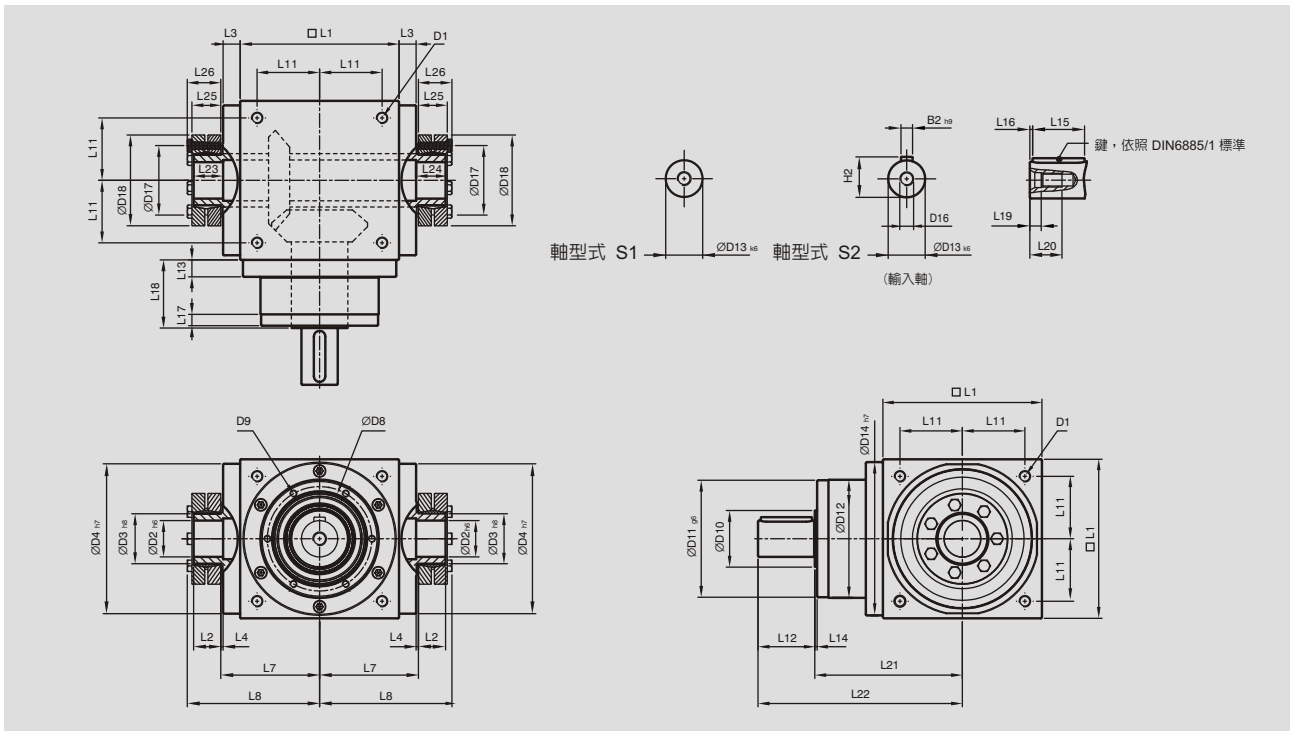

● 標準配件含 2 個縮緊盤

(單位: mm)

尺寸	AT065 C	AT075 C	AT090 C	AT110 C	AT140 C	AT170 C	AT210 C	AT240 C	AT280 C
D1	M4	M6	M6	M8	M10	M12	M16	M16	M16
D2 H6	13	14	18	22	32	40	50	55	60
D3 h8	16	16	22	25	44	50	62	68	75
D4 h7	63	73	88	108	135	165	205	235	275
D8	53	62	76	95	92	114	142	160	176
D9	4xM4xL7	4xM5xL8	4xM5xL8	6xM6xL10	6xM6xL10	6xM8xL12.5	6xM8xL12.5	6xM8xL12.5	6xM10xL15
D10	15.4	20.4	25.8	35.8	49.8	59.3	79.3	92.3	102.3
D11 g6	62.9	72.9	87	107	103	127	158	178	198
D12	62	72	86	106	104	128	160	180	200
D13 k6	13	16	18	22	32	40	50	55	60
D14 h7	63	73	88	108	135	165	205	235	275
D16	M4	M5	M5	M8	M12	M16	M16	M16	M20
D17	26	26	36	38	61	70	86	86	100
D18	41	41	50	50	80	90	110	115	138
L1	65	75	90	110	140	170	210	240	280
L2	14	14	18	18	24	26	29	29	30.5
L3	13	14.5	15	15	15	15	20	25	25
L4	2	2	2	2	2	2	2	2	2
L7	47.5	54	62	72	87	102	127	147	167
L8	66	72.5	85	95	116.5	133.5	161.5	181.5	205
L11	27	30	36	44	55	67	85	95	110
L12	19.5	30	35	40	50	60	75	85	110
L13	13	15	15	15	15	15	20	25	25
L14	2	2	2	2	2	2	2	2	2
L15	16	25	28	32	45	50	70	80	100
L16	2	2.5	3.5	4	2.5	5	2.5	2.5	5
L17	6	8	8	8	10	10	10	10	10
L18	43	52.5	55	60	60	70	90	105	120
L19	4.5	4.8	4.8	7.2	10	12	12	12	15
L20	10	12.5	12.5	19	28	36	36	36	42
L21	75.5	90	100	115	130	155	195	225	260
L22	95	120	135	155	180	215	270	310	370
L23	15	15	20	20	26	28	31	31	32.5
L24	15	15	20	20	26	28	31	31	32.5
L25	15	15	19.5	19.5	25.5	27.5	30.5	30.5	32.5
L26	18.5	18.5	23	23	29.5	31.5	34.5	34.5	38
B2 h9	5	5	6	6	10	12	14	16	18
H2	15	18	20.5	24.5	35	43	53.5	59	64

# AT-LM / RM 系列

尺寸 (單節, 減速比  $i=1$ )

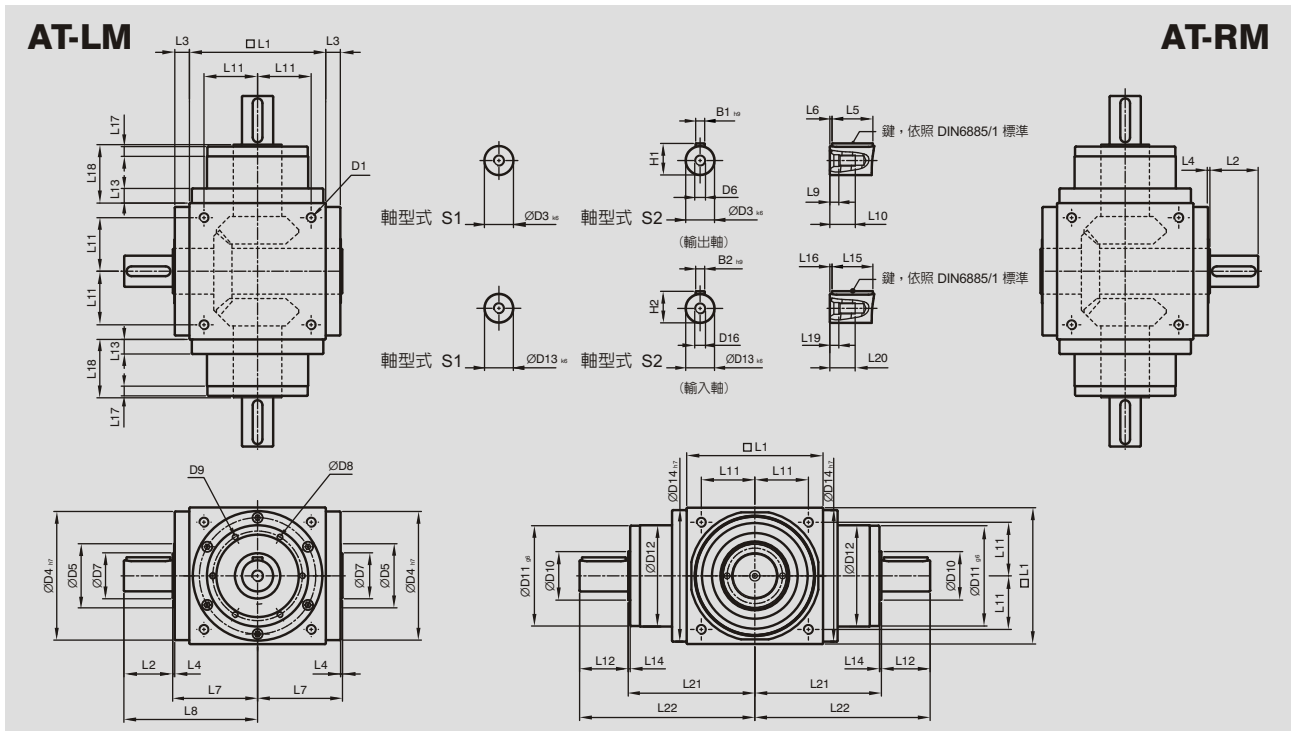

(單位: mm)

尺寸	AT065LM/RM	AT075LM/RM	AT090LM/RM	AT110LM/RM	AT140LM/RM	AT170LM/RM	AT210LM/RM	AT240LM/RM	AT280LM/RM
D1	M4	M6	M6	M8	M10	M12	M16	M16	M16
D3 <sub>k6</sub>	13	16	18	22	32	40	50	55	60
D4 <sub>h7</sub>	63	73	88	108	135	165	205	235	275
D5	31	35	43	53	68	83	104	124	144
D6	M4	M5	M5	M8	M12	M16	M16	M16	M20
D7	21	22	28	33	47	55	75	85	110
D8	53	62	76	95	92	114	142	160	176
D9	4xM4xL7	4xM5xL8	4xM5xL8	6xM6xL10	6xM6xL10	6xM8xL12.5	6xM8xL12.5	6xM8xL12.5	6xM10xL15
D10	15.4	20.4	25.8	35.8	49.8	59.3	79.3	92.3	102.3
D11 <sub>g6</sub>	62.9	72.9	87	107	103	127	158	178	198
D12	62	72	86	106	104	128	160	180	200
D13 <sub>k6</sub>	13	16	18	22	32	40	50	55	60
D14 <sub>h7</sub>	63	73	88	108	135	165	205	235	275
D16	M4	M5	M5	M8	M12	M16	M16	M16	M20
L1	65	75	90	110	140	170	210	240	280
L2	19.5	30	35	40	50	60	75	85	110
L3	13	14.5	15	15	15	15	20	25	25
L4	2	2	2	2	2	2	2	2	2
L5	16	25	28	32	45	50	70	80	100
L6	2	2.5	3.5	4	2.5	5	2.5	2.5	5
L7	47.5	54	62	72	87	102	127	147	167
L8	67	84	97	112	137	162	202	232	277
L9	4.5	4.8	4.8	7.2	10	12	12	12	15
L10	10	12.5	12.5	19	28	36	36	36	42
L11	27	30	36	44	55	67	85	95	110
L12	19.5	30	35	40	50	60	75	85	110
L13	13	15	15	15	15	15	20	25	25
L14	2	2	2	2	2	2	2	2	2
L15	16	25	28	32	45	50	70	80	100
L16	2	2.5	3.5	4	2.5	5	2.5	2.5	5
L17	6	8	8	8	10	10	10	10	10
L18	43	52.5	55	60	60	70	90	105	120
L19	4.5	4.8	4.8	7.2	10	12	12	12	15
L20	10	12.5	12.5	19	28	36	36	36	42
L21	75.5	90	100	115	130	155	195	225	260
L22	95	120	135	155	180	215	270	310	370
B1 <sub>h9</sub>	5	5	6	6	10	12	14	16	18
B2 <sub>h9</sub>	5	5	6	6	10	12	14	16	18
H1	15	18	20.5	24.5	35	43	53.5	59	64
H2	15	18	20.5	24.5	35	43	53.5	59	64



# AT-4M 系列

## 尺寸 (單節, 減速比 i=1)

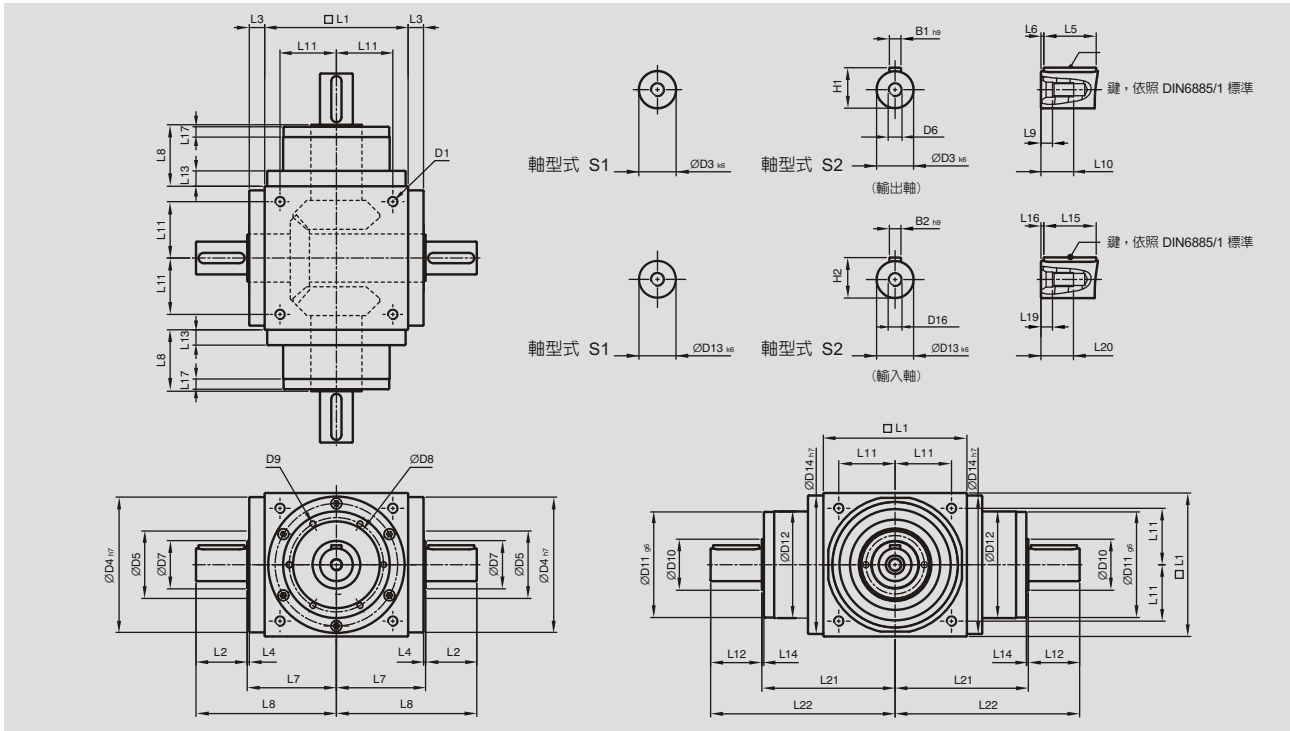

(單位: mm)

尺寸	AT065 4M	AT075 4M	AT090 4M	AT110 4M	AT140 4M	AT170 4M	AT210 4M	AT240 4M	AT280 4M
D1	M4	M6	M6	M8	M10	M12	M16	M16	M16
D3 <sub>k6</sub>	13	16	18	22	32	40	50	55	60
D4 <sub>h7</sub>	63	73	88	108	135	165	205	235	275
D5	31	35	43	53	68	83	104	124	144
D6	M4	M5	M5	M8	M12	M16	M16	M16	M20
D7	21	22	28	33	47	55	75	85	110
D8	53	62	76	95	92	114	142	160	176
D9	4xM4xL7	4xM5xL8	4xM5xL8	6xM6xL10	6xM6xL10	6xM8xL12.5	6xM8xL12.5	6xM8xL12.5	6xM10xL15
D10	15.4	20.4	25.8	35.8	49.8	59.3	79.3	92.3	102.3
D11 <sub>g6</sub>	62.9	72.9	87	107	103	127	158	178	198
D12	62	72	86	106	104	128	160	180	200
D13 <sub>k6</sub>	13	16	18	22	32	40	50	55	60
D14 <sub>h7</sub>	63	73	88	108	135	165	205	235	275
D16	M4	M5	M5	M8	M12	M16	M16	M16	M20
L1	65	75	90	110	140	170	210	240	280
L2	19.5	30	35	40	50	60	75	85	110
L3	13	14.5	15	15	15	15	20	25	25
L4	2	2	2	2	2	2	2	2	2
L5	16	25	28	32	45	50	70	80	100
L6	2	2.5	3.5	4	2.5	5	2.5	2.5	5
L7	47.5	54	62	72	87	102	127	147	167
L8	67	84	97	112	137	162	202	232	277
L9	4.5	4.8	4.8	7.2	10	12	12	12	15
L10	10	12.5	12.5	19	28	36	36	36	42
L11	27	30	36	44	55	67	85	95	110
L12	19.5	30	35	40	50	60	75	85	110
L13	13	15	15	15	15	15	20	25	25
L14	2	2	2	2	2	2	2	2	2
L15	16	25	28	32	45	50	70	80	100
L16	2	2.5	3.5	4	2.5	5	2.5	2.5	5
L17	6	8	8	8	10	10	10	10	10
L18	43	52.5	55	60	60	70	90	105	120
L19	4.5	4.8	4.8	7.2	10	12	12	12	15
L20	10	12.5	12.5	19	28	36	36	36	42
L21	75.5	90	100	115	130	155	195	225	260
L22	95	120	135	155	180	215	270	310	370
B1 <sub>h9</sub>	5	5	6	6	10	12	14	16	18
B2 <sub>h9</sub>	5	5	6	6	10	12	14	16	18
H1	15	18	20.5	24.5	35	43	53.5	59	64
H2	15	18	20.5	24.5	35	43	53.5	59	64

# AT 法蘭型系列

## 產品規格

### 減速機性能資料

規 格	節 數	比 數 <sup>1</sup>	AT065 FL	AT075 FL	AT090 FL	AT110 FL	AT140 FL	AT170 FL	AT210 FL	AT240 FL	AT280 FL	
			AT065 FL1	AT075 FL1	AT090 FL1	AT110 FL1	AT140 FL1	AT170 FL1	AT210 FL1	AT240 FL1	AT280 FL1	
			AT065 FH	AT075 FH	AT090 FH	AT110 FH	AT140 FH	AT170 FH	AT210 FH	AT240 FH	AT280 FH	
			AT065 FC	AT075 FC	AT090 FC	AT110 FC	AT140 FC	AT170 FC	AT210 FC	AT240 FC	AT280 FC	
			AT065 FR1	AT075 FR1	AT090 FR1	AT110 FR1	AT140 FR1	AT170 FR1	AT210 FR1	AT240 FR1	AT280 FR1	
額定輸出力矩 $T_{2N}$	1	1	25	45	78	150	360	585	1,300	2,150	3,200	
		1.5	25	45	78	150	360	585	1,300	2,150	3,200	
		2	24	42	68	150	330	544	1,220	2,010	3,050	
		3	18	33	54	120	270	450	1,020	1,650	2,850	
		4	13	28	48	100	224	376	860	1,410	2,300	
		5	12	25	40	85	196	320	740	1,210	2,000	
	2	7	12	12	33	91	91	91	195	358	358	
		10	24	28	68	150	208	208	430	846	846	
		15	18	33	54	120	270	312	645	1,269	1,269	
		20	13	28	48	100	224	376	860	1,410	1,692	
		25	12	25	40	85	196	320	740	1,210	2,000	
		35	12	25	40	85	196	320	740	1,210	1,790	
		50	12	25	40	85	196	320	740	1,210	1,465	
	3	75	-	-	-	120	210	312	585	1,269	1,269	
		100	-	-	-	100	224	376	780	1,410	1,692	
		125	-	-	-	85	196	320	740	1,210	2,000	
		150	-	-	-	120	135	312	390	975	975	
		200	-	-	-	100	180	376	520	1,300	1,300	
		250	-	-	-	85	196	320	650	1,210	1,625	
		350	-	-	-	85	196	320	740	1,210	1,790	
		500	-	-	-	85	196	320	740	1,210	1,465	
最大加速力矩 $T_{2B}$	Nm	1,2,3	1~500	1.5 倍額定輸出力矩								
最大加速輸入轉速 $n_{1B}$	rpm	1	1~5	7,500	6,500	5,500	4,500	3,500	3,000	2,200	2,000	1,700
		2	7~50	8,000	8,000	6,000	6,000	6,000	6,000	4,800	3,600	3,600
		3	75~500	-	-	-	8,000	8,000	6,000	6,000	6,000	6,000
背隙 <sup>*</sup>	arcmin	1	1~5	≤6	≤6	≤6	≤6	≤6	≤6	≤6	≤6	≤6
		2	7~50	≤8	≤8	≤8	≤8	≤8	≤8	≤8	≤8	≤8
		3	75~500	-	-	-	≤10	≤10	≤10	≤10	≤10	≤10
容許徑向力 $F_{z2B}$ <sup>2</sup> 輸出軸 d2	N	1,2,3	1~500	900	1,100	1,700	2,700	4,800	6,600	11,500	16,000	18,000
容許軸向力 $F_{z2aB}$ <sup>2</sup> 輸出軸 d2	N	1,2,3	1~500	450	550	850	1,350	2,400	3,300	5,750	8,500	9,000
使用壽命	hr	1,2,3	1~500	20,000*								
效率 $\eta$	%	1	1~5	≥98%								
		2,3	7~500	≥94%								
使用溫度	°C	1,2,3	1~500	-10°C ~ 90°C								
潤滑				合成潤滑油脂								
噪音值 ( $n_1=1500\text{rpm}$ , 無負載)	dB (A)	1,2,3	1~500	≤71	≤72	≤76	≤77	≤78	≤79	≤81	≤83	≤84

1. 減速比 ( $i=N_{in}/N_{out}$ )

\* 連續運轉降低使用壽命二分之一。

2. 作用於輸出軸中心位置 @  $n_{1B}$

\* 背隙值為在 2% 額定力矩  $T_{2N}$  的扭力下所測得

# AT 法蘭型系列

## 產品規格



### 減速機轉動慣量

規 格	節 數	比 數	AT065 FL	AT075 FL	AT090 FL	AT110 FL	AT140 FL	AT170 FL	AT210 FL	AT240 FL	AT280 FL	
			AT065 FL1	AT075 FL1	AT090 FL1	AT110 FL1	AT140 FL1	AT170 FL1	AT210 FL1	AT240 FL1	AT280 FL1	
轉動慣量 J,	kg · cm <sup>2</sup>	1	AT065 FH	AT075 FH	AT090 FH	AT110 FH	AT140 FH	AT170 FH	AT210 FH	AT240 FH	AT280 FH	
			AT065 FC	AT075 FC	AT090 FC	AT110 FC	AT140 FC	AT170 FC	AT210 FC	AT240 FC	AT280 FC	
		2	AT065 FR1	AT075 FR1	AT090 FR1	AT110 FR1	AT140 FR1	AT170 FR1	AT210 FR1	AT240 FR1	AT280 FR1	
			AT065 FR1	AT075 FR1	AT090 FR1	AT110 FR1	AT140 FR1	AT170 FR1	AT210 FR1	AT240 FR1	AT280 FR1	
		1	1	0.51	1.30	3.14	7.62	23.54	59.09	195.96	365.38	787.63
			1.5	0.46	1.15	2.80	6.65	19.34	49.38	156.02	279.62	584.28
			2	0.44	1.10	2.68	6.23	17.72	45.44	140.80	245.78	500.26
			3	0.43	1.09	2.64	6.08	17.16	44.11	135.51	233.75	471.56
			4	0.43	1.08	2.63	6.05	17.03	43.79	134.14	230.77	464.76
			5	0.43	1.08	2.63	6.04	16.99	43.69	133.71	229.71	462.08
		2	7	0.15	0.15	0.50	2.79	2.79	2.79	9.91	29.26	29.26
			10	0.15	0.15	0.50	2.80	2.80	2.80	9.96	29.43	29.43
			15	0.15	0.15	0.50	2.80	2.80	2.80	9.96	29.43	29.43
			20	0.15	0.15	0.50	2.80	2.80	2.80	9.96	29.43	29.43
			25	0.15	0.15	0.50	2.80	2.80	2.80	9.96	29.43	29.43
			35	0.15	0.15	0.50	2.79	2.79	2.79	9.91	29.26	29.26
			50	0.15	0.15	0.50	2.79	2.79	2.79	9.89	29.20	29.20
			75	-	-	-	2.80	2.80	2.80	9.96	29.43	29.43
			100	-	-	-	2.80	2.80	2.80	9.96	29.43	29.43
			125	-	-	-	2.80	2.80	2.80	9.96	29.43	29.43
		3	150	-	-	-	2.79	2.79	2.79	9.89	29.20	29.20
			200	-	-	-	2.79	2.79	2.79	9.89	29.20	29.20
			250	-	-	-	2.79	2.79	2.79	9.89	29.20	29.20
			350	-	-	-	2.79	2.79	2.79	9.89	29.20	29.20
			500	-	-	-	2.79	2.79	2.79	9.89	29.20	29.20

### 重量

減 速 機 型 號	節 數	比 數	AT065	AT075	AT090	AT110	AT140	AT170	AT210	AT240	AT280
FL 系列	1	1~5	2.8	4.4	7.1	12.1	20.9	36.1	69.4	101.2	158.3
	2	7~50	3.2	4.8	8.1	14.3	24.2	38.5	74.1	112.4	171.0
	3	75~500	-	-	-	13.9	23.7	38.8	73.4	110.2	168.7
FL1 系列	1	1~5	2.7	4.3	7.1	11.9	20.3	35.5	68.3	99.6	156.0
	2	7~50	3.2	4.8	8.0	14.2	23.9	37.9	73.0	110.8	168.6
	3	75~500	-	-	-	13.8	23.4	38.2	72.3	108.6	166.4
FH 系列	1	1~5	2.6	4.1	6.7	11.4	18.9	32.9	63.2	92.5	146.0
	2	7~50	3.1	4.6	7.7	13.6	22.4	35.3	67.9	103.7	158.7
	3	75~500	-	-	-	13.3	21.9	35.6	67.2	101.5	156.5
FC 系列	1	1~5	2.9	4.4	7.2	11.8	20.4	35.0	66.5	96.0	151.7
	2	7~50	3.3	4.9	8.2	14.1	24.1	37.4	71.2	107.2	164.4
	3	75~500	-	-	-	13.7	23.5	37.5	70.5	105.0	162.2
FR1 系列	1	1~5	2.7	4.3	7.1	11.9	20.3	35.5	68.3	99.6	156.0
	2	7~50	3.2	4.8	8.0	14.2	23.9	37.9	73.0	110.8	168.6
	3	75~500	-	-	-	13.8	23.4	38.2	72.3	108.6	166.4

# AT-FL 系列

## 尺寸 (單節, 減速比 i=1~5)

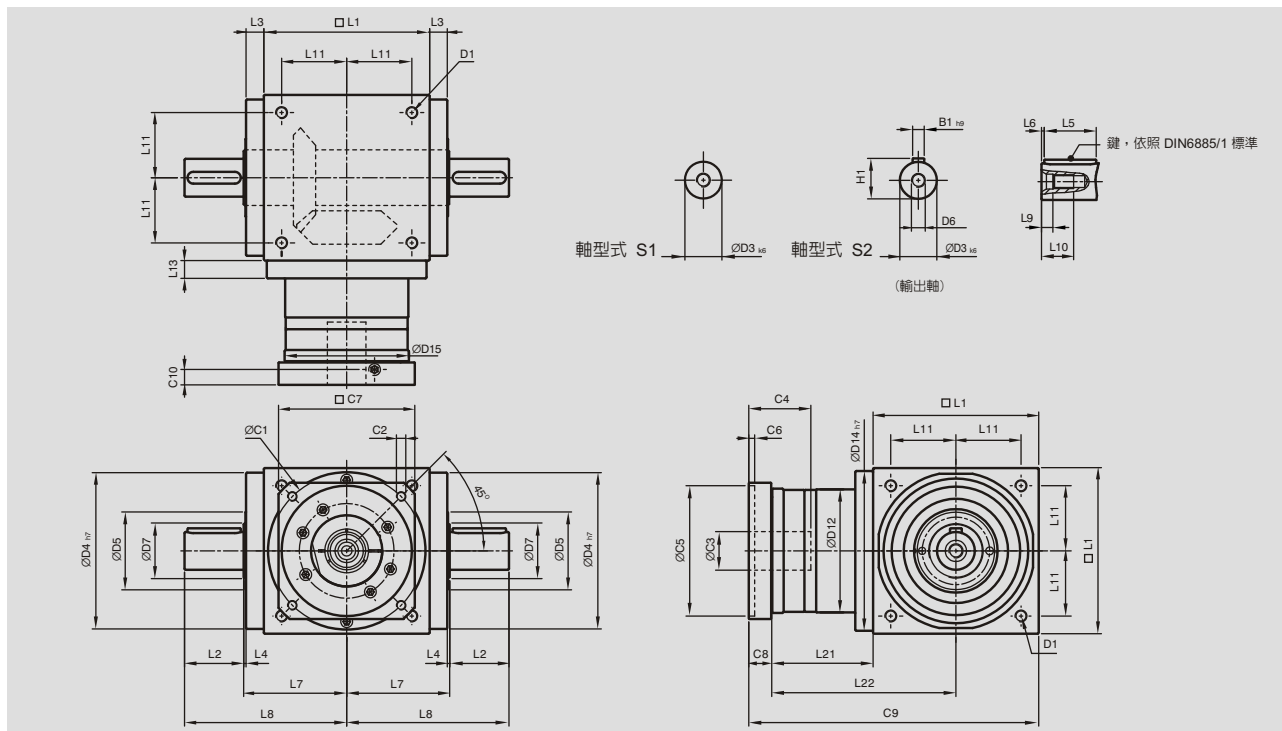

(單位: mm)

尺寸	AT065 FL	AT075 FL	AT090 FL	AT110 FL	AT140 FL	AT170 FL	AT210 FL	AT240 FL	AT280 FL
D1	M4	M6	M6	M8	M10	M12	M16	M16	M16
D3 <sub>k6</sub>	13	16	18	22	32	40	50	55	60
D4 <sub>h7</sub>	63	73	88	108	135	165	205	235	275
D5	31	35	43	53	68	83	104	124	144
D6	M4	M5	M5	M8	M12	M16	M16	M16	M20
D7	21	22	28	33	47	55	75	85	110
D12	62	72	86	106	104	128	160	180	200
D14 <sub>h7</sub>	63	73	88	108	135	165	205	235	275
D15	62.9	72.9	87	107	105	127	158	178	198
L1	65	75	90	110	140	170	210	240	280
L2	19.5	30	35	40	50	60	75	85	110
L3	13	14.5	15	15	15	15	20	25	25
L4	2	2	2	2	2	2	2	2	2
L5	16	25	28	32	45	50	70	80	100
L6	2	2.5	3.5	4	2.5	5	2.5	2.5	5
L7	47.5	54	62	72	87	102	127	147	167
L8	67	84	97	112	137	162	202	232	277
L9	4.5	4.8	4.8	7.2	10	12	12	12	15
L10	10	12.5	12.5	19	28	36	36	36	42
L11	27	30	36	44	55	67	85	95	110
L13	13	15	15	15	15	15	20	25	25
L21	49	60.5	63	69.5	85.5	95	130	144.5	135
L22	81.5	98	108	124.5	155.5	180	235	264.5	275
C1 <sup>3</sup>	46	70	100	100	130	165	215	215	235
C2 <sup>3</sup>	M4	M5	M6	M6	M8	M10	M12	M12	M12
C3 <sup>3</sup>	★ ≤11 / ≤12	★ ≤14 / ≤15.875 / ≤16	≤19	≤24	≤32	≤38	≤42	≤48	≤55
C4 <sup>3</sup>	30	34	40	40	50	60	85	85	116
C5 <sup>3</sup>	30	50	80	80	110	130	180	180	200
C6 <sup>3</sup>	3.5	8	4	4	5	6	6	6	6
C7 <sup>3</sup>	42	60	90	90	115	142	190	190	220
C8 <sup>3</sup>	19.5	19	17	17	19.5	22.5	29	29	63
C9 <sup>3</sup>	133.5	154.5	170	196.5	245	287.5	369	413.5	478
C10 <sup>3</sup>	13.25	13.5	10.75	10.75	13	15	20.75	20.75	53.5
B1 <sub>h9</sub>	5	5	6	6	10	12	14	16	18
H1	15	18	20.5	24.5	35	43	53.5	59	64

3. C1~C10 是公制標準馬達連接板之尺寸, 請上網點選"減速機選用" 找出正確之尺寸。

★ AT065 FLM1 提供 C3 ≤12 option. ★ AT075 FLM1 提供 C3 ≤16 option. ★ AT075 FLM2 提供 C3 ≤15.875 option.

# AT-FL 系列

## 尺寸 (雙節, 減速比 $i=7\sim 50$ )

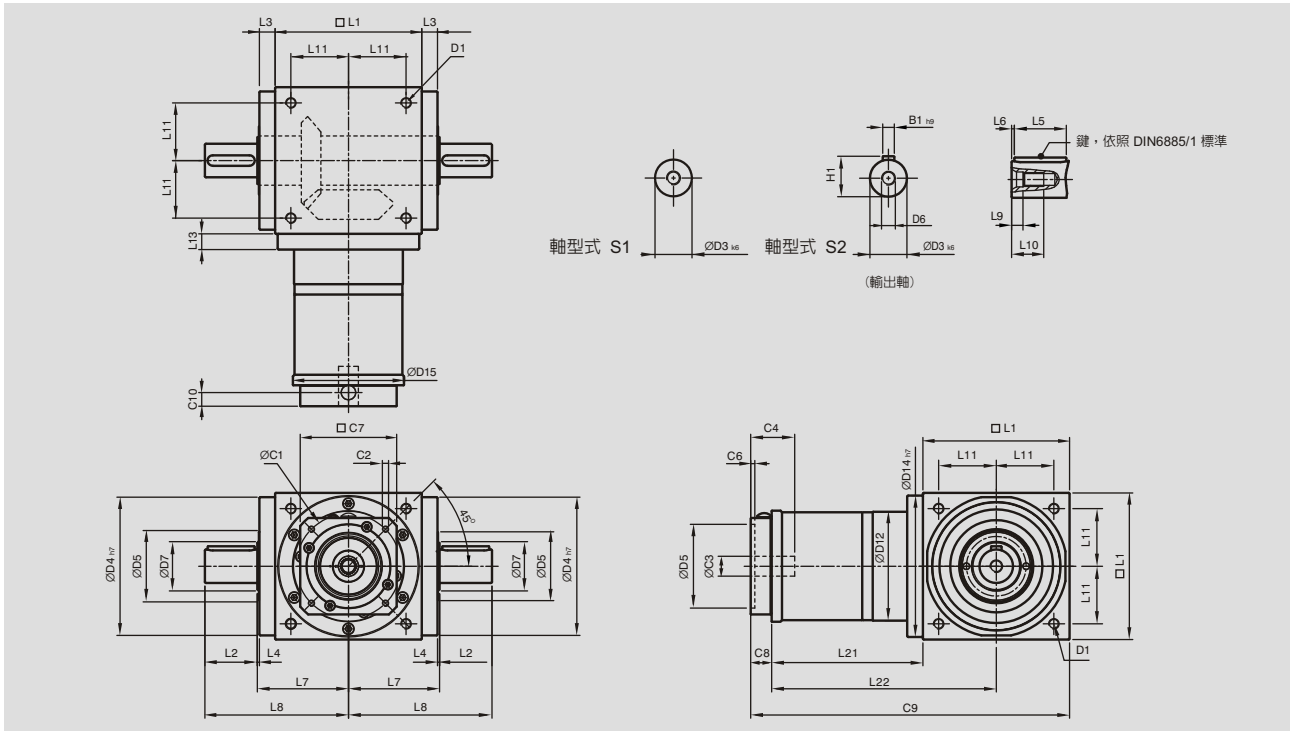

(單位: mm)

尺寸	AT065 FL	AT075 FL	AT090 FL	AT110 FL	AT140 FL	AT170 FL	AT210 FL	AT240 FL	AT280 FL
D1	M4	M6	M6	M8	M10	M12	M16	M16	M16
D3 k6	13	16	18	22	32	40	50	55	60
D4 h7	63	73	88	108	135	165	205	235	275
D5	31	35	43	53	68	83	104	124	144
D6	M4	M5	M5	M8	M12	M16	M16	M16	M20
D7	21	22	28	33	47	55	75	85	110
D12	62	72	86	106	104	128	160	180	200
D14 h7	63	73	88	108	135	165	205	235	275
D15	62.9	72.9	87	107	106	127	158	178	198
L1	65	75	90	110	140	170	210	240	280
L2	19.5	30	35	40	50	60	75	85	110
L3	13	14.5	15	15	15	15	20	25	25
L4	2	2	2	2	2	2	2	2	2
L5	16	25	28	32	45	50	70	80	100
L6	2	2.5	3.5	4	2.5	5	2.5	2.5	5
L7	47.5	54	62	72	87	102	127	147	167
L8	67	84	97	112	137	162	202	232	277
L9	4.5	4.8	4.8	7.2	10	12	12	12	15
L10	10	12.5	12.5	19	28	36	36	36	42
L11	27	30	36	44	55	67	85	95	110
L13	13	15	15	15	15	15	20	25	25
L21	75	84.5	99	122	144.5	157.5	206.5	239	248
L22	107.5	122	144	177	214.5	242.5	311.5	359	388
C1 <sup>4</sup>	46	46	70	100	100	100	130	165	165
C2 <sup>4</sup>	M4	M4	M5	M6	M6	M6	M8	M10	M10
C3 <sup>4</sup>	≤12	≤12	≤16	≤24	≤24	≤24	≤32	≤38	≤38
C4 <sup>4</sup>	30	30	34	40	40	40	50	60	60
C5 <sup>4</sup>	30	30	50	80	80	80	110	130	130
C6 <sup>4</sup>	3.5	3.5	8	4	4	4	5	6	6
C7 <sup>4</sup>	42	42	60	92	92	92	115	142	142
C8 <sup>4</sup>	21.5	21.5	21.5	20	20	20	24	31	31
C9 <sup>4</sup>	161.5	181	210.5	252	304.5	347.5	440.5	510	559
C10 <sup>4</sup>	14.5	14.5	15.5	13	13	13	16	21	21
B1 h9	5	5	6	6	10	12	14	16	18
H1	15	18	20.5	24.5	35	43	53.5	59	64

4. C1-C10 是公制標準馬達連接板之尺寸, 請上網點選“減速機選用”找出正確之尺寸。

# AT-FL 系列

## 尺寸 (三節, 減速比 $i=75\sim 500$ )

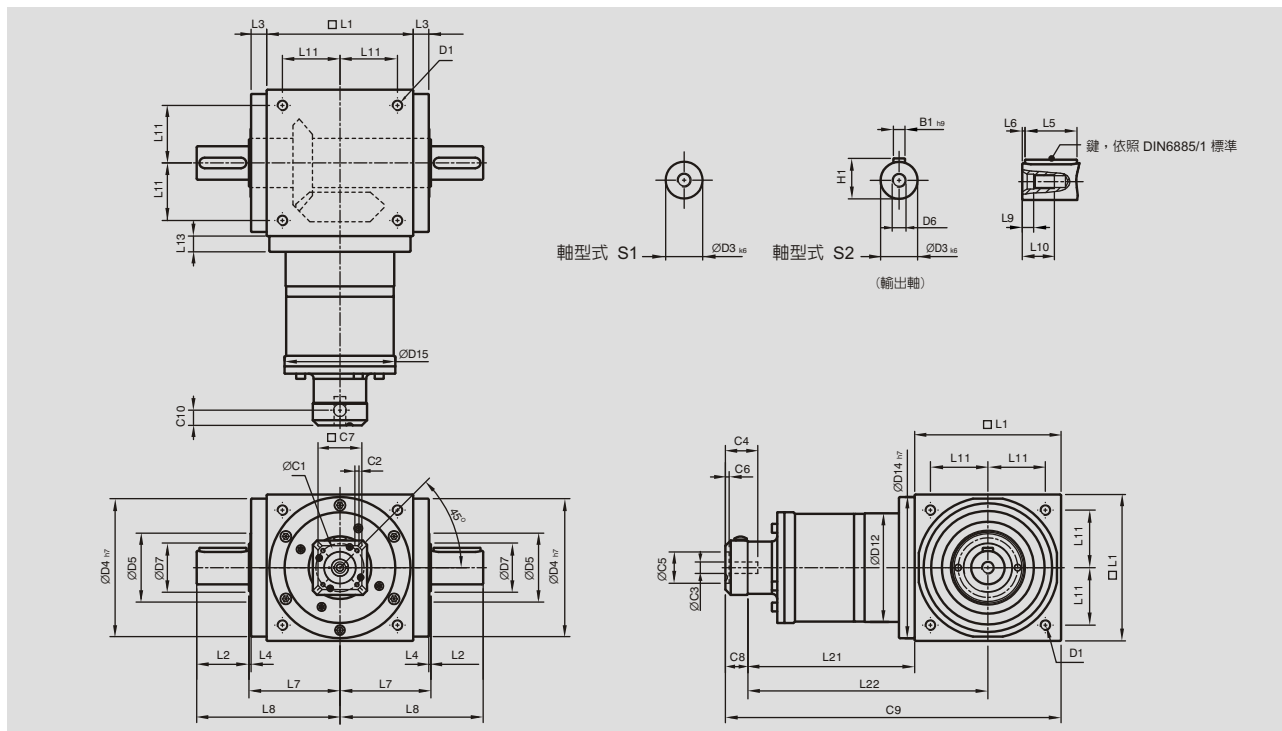

(單位: mm)

尺寸	AT110 FL	AT140 FL	AT170 FL	AT210 FL	AT240 FL	AT280 FL
D1	M8	M10	M12	M16	M16	M16
D3 <sub>k6</sub>	22	32	40	50	55	60
D4 <sub>h7</sub>	108	135	165	205	235	275
D5	53	68	83	104	124	144
D6	M8	M12	M16	M16	M16	M20
D7	33	47	55	75	85	110
D12	106	104	128	160	180	200
D14 <sub>h7</sub>	108	135	165	205	235	275
D15	107	106	127	158	178	198
L1	110	140	170	210	240	280
L2	40	50	60	75	85	110
L3	15	15	15	20	25	25
L4	2	2	2	2	2	2
L5	32	45	50	70	80	100
L6	4	2.5	5	2.5	2.5	5
L7	72	87	102	127	147	167
L8	112	137	162	202	232	277
L9	7.2	10	12	12	12	15
L10	19	28	36	36	36	42
L11	44	55	67	85	95	110
L13	15	15	15	20	25	25
L21	136.5	159.5	183.5	226	269	278
L22	191.5	229.5	268.5	331	389	418
C1 <sup>5</sup>	46	46	70	70	100	100
C2 <sup>5</sup>	M4	M4	M5	M5	M6	M6
C3 <sup>5</sup>	≤12	≤12	≤16	≤16	≤24	≤24
C4 <sup>5</sup>	30	30	34	34	40	40
C5 <sup>5</sup>	30	30	50	50	80	80
C6 <sup>5</sup>	3.5	3.5	8	8	4	4
C7 <sup>5</sup>	42	42	60	60	92	92
C8 <sup>5</sup>	21.5	21.5	21.5	21.5	20	20
C9 <sup>5</sup>	268	321	375	457.5	529	578
C10 <sup>5</sup>	14.5	14.5	15.5	15.5	13	13
B1 <sub>h9</sub>	6	10	12	14	16	18
H1	24.5	35	43	53.5	59	64

5. C1-C10 是公制標準馬達連接板之尺寸, 請上網點選"減速機選用"找出正確之尺寸。

# AT-FL1 / FR1 系列

## 尺寸 (單節, 減速比 i=1~5)

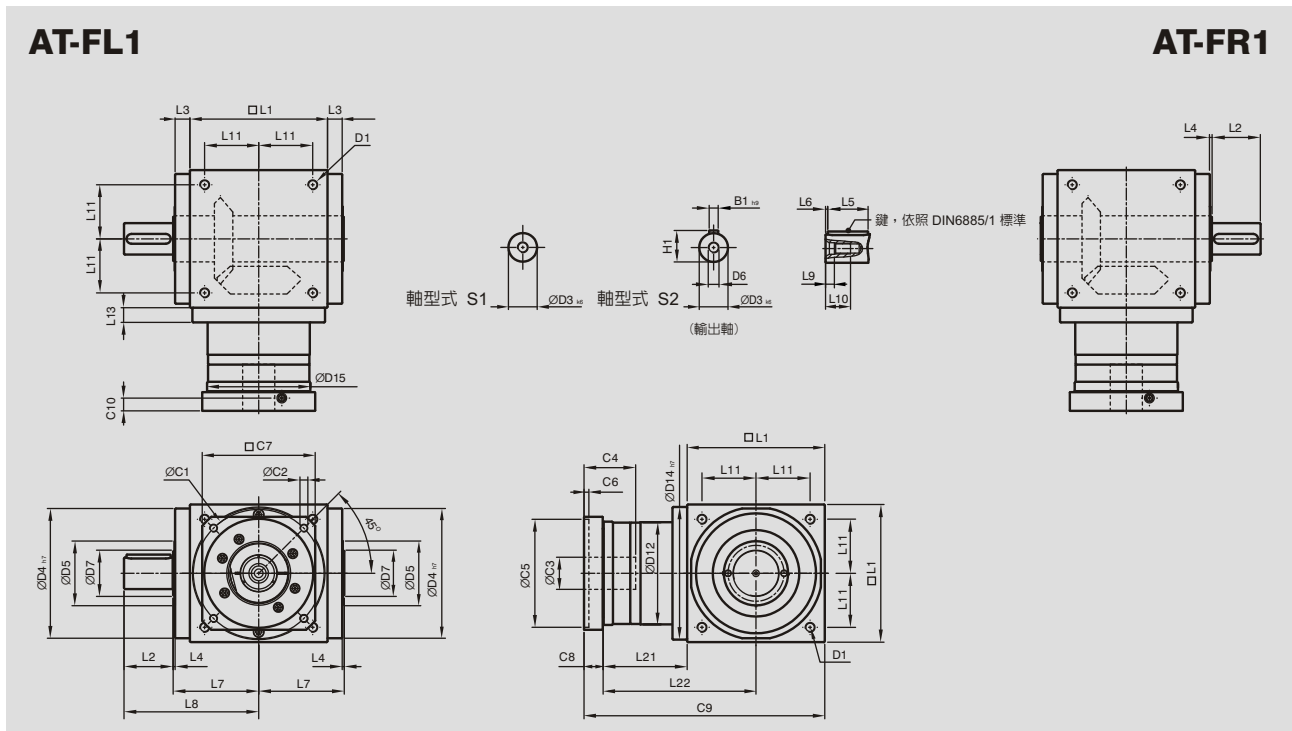

(單位: mm)

尺寸	AT065 FL1/FR1	AT075 FL1/FR1	AT090 FL1/FR1	AT110 FL1/FR1	AT140 FL1/FR1	AT170 FL1/FR1	AT210 FL1/FR1	AT240 FL1/FR1	AT280 FL1/FR1
D1	M4	M6	M6	M8	M10	M12	M16	M16	M16
D3 k6	13	16	18	22	32	40	50	55	60
D4 h7	63	73	88	108	135	165	205	235	275
D5	31	35	43	53	68	83	104	124	144
D6	M4	M5	M5	M8	M12	M16	M16	M16	M20
D7	21	22	28	33	47	55	75	85	110
D12	62	72	86	106	104	128	160	180	200
D14 h7	63	73	88	108	135	165	205	235	275
D15	62.9	72.9	87	107	105	127	158	178	198
L1	65	75	90	110	140	170	210	240	280
L2	19.5	30	35	40	50	60	75	85	110
L3	13	14.5	15	15	15	15	20	25	25
L4	2	2	2	2	2	2	2	2	2
L5	16	25	28	32	45	50	70	80	100
L6	2	2.5	3.5	4	2.5	5	2.5	2.5	5
L7	47.5	54	62	72	87	102	127	147	167
L8	67	84	97	112	137	162	202	232	277
L9	4.5	4.8	4.8	7.2	10	12	12	12	15
L10	10	12.5	12.5	19	28	36	36	36	42
L11	27	30	36	44	55	67	85	95	110
L13	13	15	15	15	15	15	20	25	25
L21	49	60.5	63	69.5	85.5	95	130	144.5	135
L22	81.5	98	108	124.5	155.5	180	235	264.5	275
C1 <sup>6</sup>	46	70	100	100	130	165	215	215	235
C2 <sup>6</sup>	M4	M5	M6	M6	M8	M10	M12	M12	M12
C3 <sup>6</sup>	★ ≤11 / ≤12	★ ≤14 / ≤15.875 / ≤16	≤19	≤24	≤32	≤38	≤42	≤48	≤55
C4 <sup>6</sup>	30	34	40	40	50	60	85	85	116
C5 <sup>6</sup>	30	50	80	80	110	130	180	180	200
C6 <sup>6</sup>	3.5	8	4	4	5	6	6	6	6
C7 <sup>6</sup>	42	60	90	90	115	142	190	190	220
C8 <sup>6</sup>	19.5	19	17	17	19.5	22.5	29	29	63
C9 <sup>6</sup>	133.5	154.5	170	196.5	245	287.5	369	413.5	478
C10 <sup>6</sup>	13.25	13.5	10.75	10.75	13	15	20.75	20.75	53.5
B1 h9	5	5	6	6	10	12	14	16	18
H1	15	18	20.5	24.5	35	43	53.5	59	64

6. C1-C10 是公制標準馬達連接板之尺寸, 請上網點選"減速機選用" 找出正確之尺寸。

★ AT065 FL1/FR1M1 提供 C3 ≤12 option. ★ AT075 FL1/FR1M1 提供 C3 ≤16 option. ★ AT075 FL1/FR1M2 提供 C3 ≤15.875 option.

# AT-FL1 / FR1 系列

## 尺寸 (雙節, 減速比 $i=7\sim 50$ )

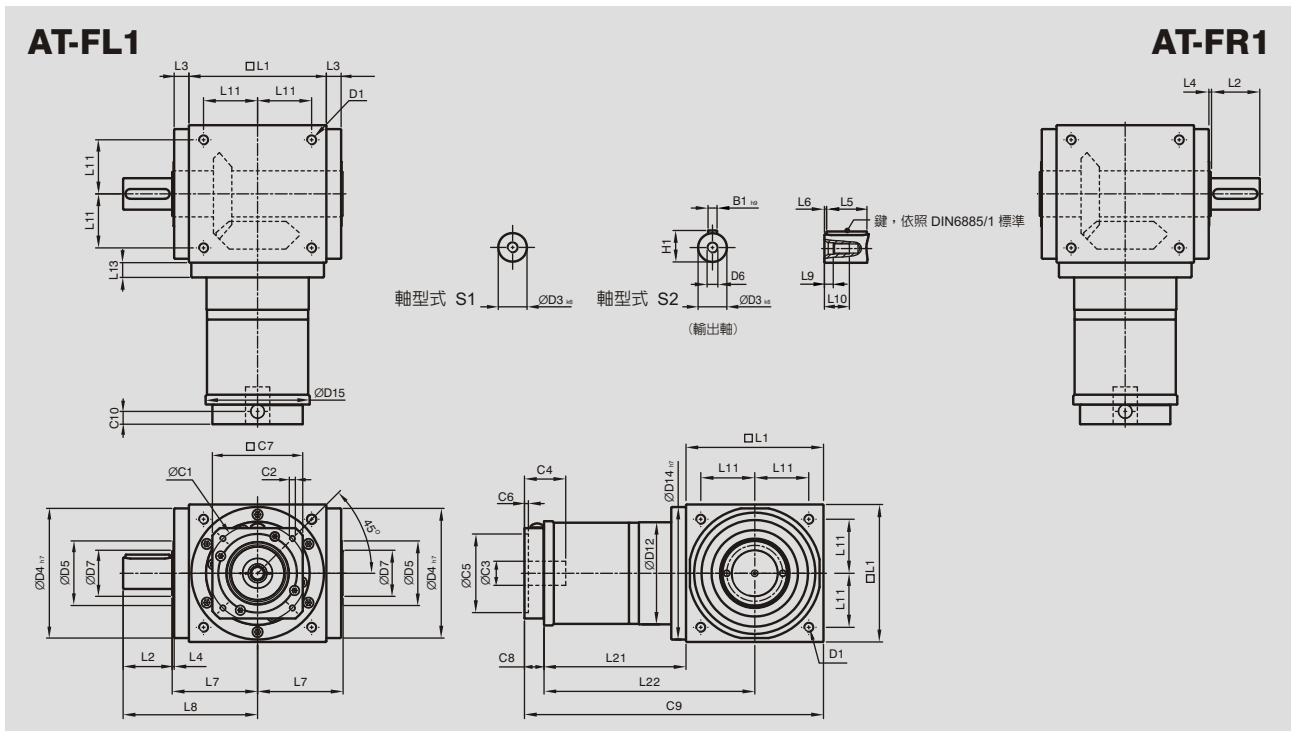

(單位: mm)

尺寸	AT065 FL1/FR1	AT075 FL1/FR1	AT090 FL1/FR1	AT110 FL1/FR1	AT140 FL1/FR1	AT170 FL1/FR1	AT210 FL1/FR1	AT240 FL1/FR1	AT280 FL1/FR1
D1	M4	M6	M6	M8	M10	M12	M16	M16	M16
D3 <sub>k6</sub>	13	16	18	22	32	40	50	55	60
D4 <sub>h7</sub>	63	73	88	108	135	165	205	235	275
D5	31	35	43	53	68	83	104	124	144
D6	M4	M5	M5	M8	M12	M16	M16	M16	M20
D7	21	22	28	33	47	55	75	85	110
D12	62	72	86	106	104	128	160	180	200
D14 <sub>h7</sub>	63	73	88	108	135	165	205	235	275
D15	62.9	72.9	87	107	106	127	158	178	198
L1	65	75	90	110	140	170	210	240	280
L2	19.5	30	35	40	50	60	75	85	110
L3	13	14.5	15	15	15	15	20	25	25
L4	2	2	2	2	2	2	2	2	2
L5	16	25	28	32	45	50	70	80	100
L6	2	2.5	3.5	4	2.5	5	2.5	2.5	5
L7	47.5	54	62	72	87	102	127	147	167
L8	67	84	97	112	137	162	202	232	277
L9	4.5	4.8	4.8	7.2	10	12	12	12	15
L10	10	12.5	12.5	19	28	36	36	36	42
L11	27	30	36	44	55	67	85	95	110
L13	13	15	15	15	15	15	20	25	25
L21	75	84.5	99	122	144.5	157.5	206.5	239	248
L22	107.5	122	144	177	214.5	242.5	311.5	359	388
C1 <sup>7</sup>	46	46	70	100	100	100	130	165	165
C2 <sup>7</sup>	M4	M4	M5	M6	M6	M6	M8	M10	M10
C3 <sup>7</sup>	≤12	≤12	≤16	≤24	≤24	≤24	≤32	≤38	≤38
C4 <sup>7</sup>	30	30	34	40	40	40	50	60	60
C5 <sup>7</sup>	30	30	50	80	80	80	110	130	130
C6 <sup>7</sup>	3.5	3.5	8	4	4	4	5	6	6
C7 <sup>7</sup>	42	42	60	92	92	92	115	142	142
C8 <sup>7</sup>	21.5	21.5	21.5	20	20	20	24	31	31
C9 <sup>7</sup>	161.5	181	210.5	252	304.5	347.5	440.5	510	559
C10 <sup>7</sup>	14.55	14.5	15.5	13	13	13	16	21	21
B1 <sub>h9</sub>	5	5	6	6	10	12	14	16	18
H1	15	18	20.5	24.5	35	43	53.5	59	64

7. C1-C10 是公制標準馬達連接板之尺寸, 請上網點選"減速機選用"找出正確之尺寸。



# AT-FL1 / FR1 系列

## 尺寸 (三節, 減速比 $i=75\sim500$ )

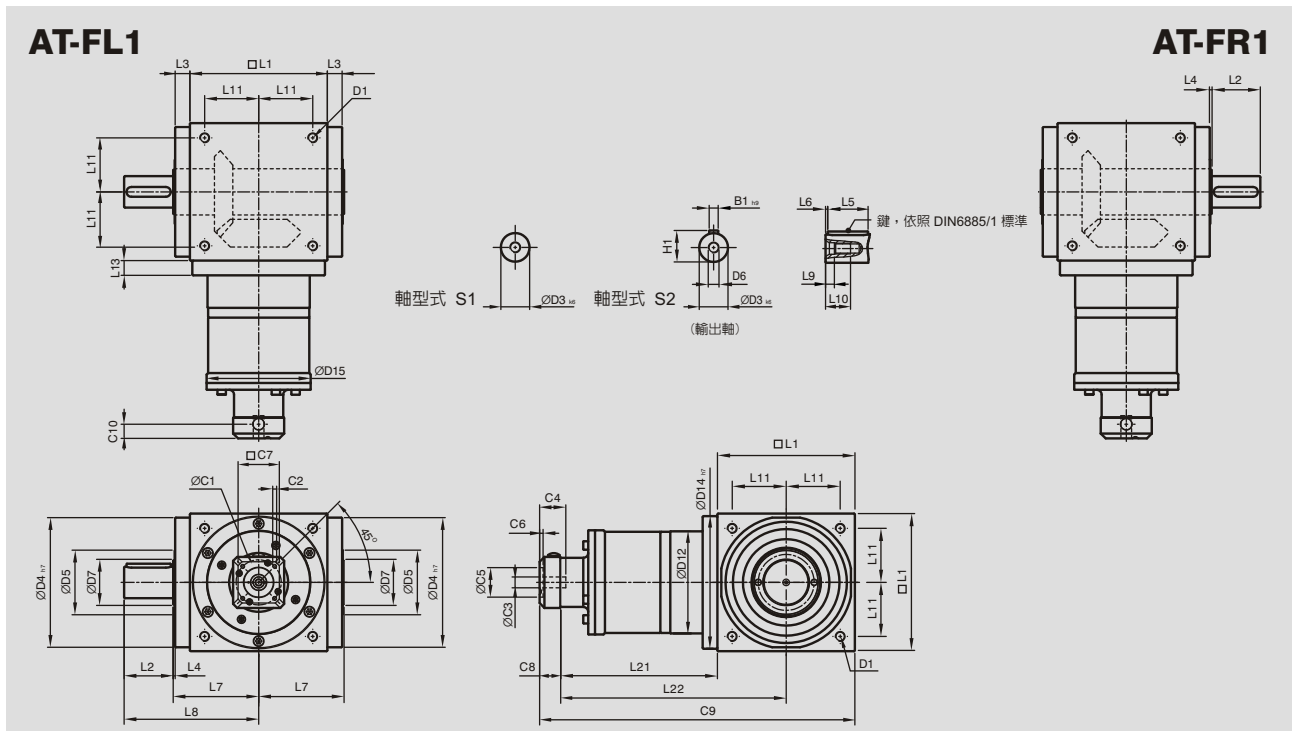

(單位: mm)

尺寸	AT110 FL1/FR1	AT140 FL1/FR1	AT170 FL1/FR1	AT210 FL1/FR1	AT240 FL1/FR1	AT280 FL1/FR1
D1	M8	M10	M12	M16	M16	M16
D3 <sub>k6</sub>	22	32	40	50	55	60
D4 <sub>h7</sub>	108	135	165	205	235	275
D5	53	68	83	104	124	144
D6	M8	M12	M16	M16	M16	M20
D7	33	47	55	75	85	110
D12	106	104	128	160	180	200
D14 <sub>h7</sub>	108	135	165	205	235	275
D15	107	106	127	158	178	198
L1	110	140	170	210	240	280
L2	40	50	60	75	85	110
L3	15	15	15	20	25	25
L4	2	2	2	2	2	2
L5	32	45	50	70	80	100
L6	4	2.5	5	2.5	2.5	5
L7	72	87	102	127	147	167
L8	112	137	162	202	232	277
L9	7.2	10	12	12	12	15
L10	19	28	36	36	36	42
L11	44	55	67	85	95	110
L13	15	15	15	20	25	25
L21	136.5	159.5	183.5	226	269	278
L22	191.5	229.5	268.5	331	389	418
C1 <sup>8</sup>	46	46	70	70	100	100
C2 <sup>8</sup>	M4	M4	M5	M5	M6	M6
C3 <sup>8</sup>	≤12	≤12	≤16	≤16	≤24	≤24
C4 <sup>8</sup>	30	30	34	34	40	40
C5 <sup>8</sup>	30	30	50	50	80	80
C6 <sup>8</sup>	3.5	3.5	8	8	4	4
C7 <sup>8</sup>	42	42	60	60	92	92
C8 <sup>8</sup>	21.5	21.5	21.5	21.5	20	20
C9 <sup>8</sup>	268	321	375	457.5	529	578
C10 <sup>8</sup>	14.5	14.5	15.5	15.5	13	13
B1 <sub>h9</sub>	6	10	12	14	16	18
H1	24.5	35	43	53.5	59	64

8. C1-C10 是公制標準馬達連接板之尺寸, 請上網點選"減速機選用" 找出正確之尺寸。

# AT-FH 系列

## 尺寸 (單節, 減速比 i=1~5)

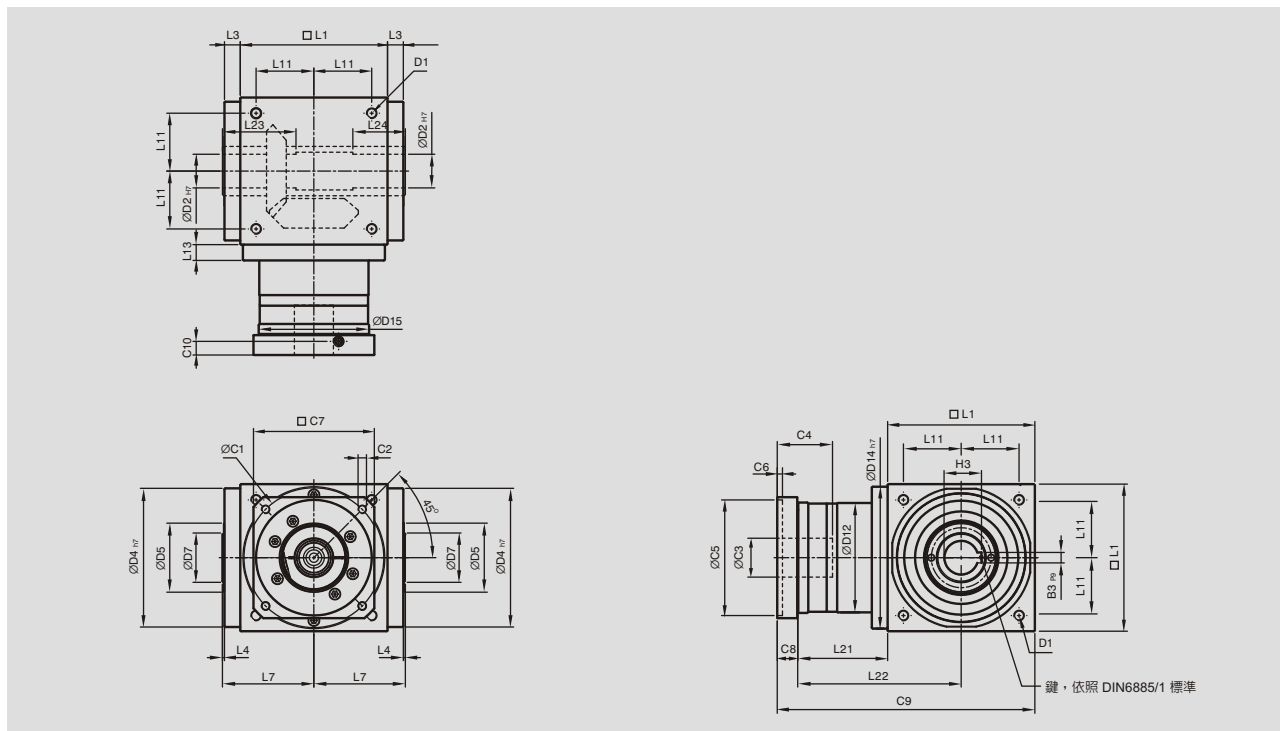

(單位: mm)

尺寸	AT065FH	AT075FH	AT090FH	AT110FH	AT140FH	AT170FH	AT210FH	AT240FH	AT280FH
D1	M4	M6	M6	M8	M10	M12	M16	M16	M16
D2 h7	13	14	18	22	32	40	50	55	60
D4 h7	63	73	88	108	135	165	205	235	275
D5	31	35	43	53	68	83	104	124	144
D7	21	22	28	33	47	55	75	85	110
D12	62	72	86	106	104	128	160	180	200
D14 h7	63	73	88	108	135	165	205	235	275
D15	62.9	72.9	87	107	105	127	158	178	198
L1	65	75	90	110	140	170	210	240	280
L3	13	14.5	15	15	15	15	20	25	25
L4	2	2	2	2	2	2	2	2	2
L7	47.5	54	62	72	87	102	127	147	167
L11	27	30	36	44	55	67	85	95	110
L13	13	15	15	15	15	15	20	25	25
L21	49	60.5	63	69.5	85.5	95	130	144.5	135
L22	81.5	98	108	124.5	155.5	180	235	264.5	275
L23	40	47	52	53	70	80	95	115	115
L24	30	32	35	35	50	55	65	80	80
C1°	46	70	100	100	130	165	215	215	235
C2°	M4	M5	M6	M6	M8	M10	M12	M12	M12
C3°	★ ≤11 / ≤12	★ ≤14 / ≤15.875 / ≤16	≤19	≤24	≤32	≤38	≤42	≤48	≤55
C4°	30	34	40	40	50	60	85	85	116
C5°	30	50	80	80	110	130	180	180	200
C6°	3.5	8	4	4	5	6	6	6	6
C7°	42	60	90	90	115	142	190	190	220
C8°	19.5	19	17	17	19.5	22.5	29	29	63
C9°	133.5	154.5	170	196.5	245	287.5	369	413.5	478
C10°	13.25	13.5	10.75	10.75	13	15	20.75	20.75	53.5
B3 P9	5	5	6	6	10	12	14	16	18
H3	15.3	16.3	20.8	24.8	35.3	43.3	53.8	59.3	64.4

9. C1~C10 是公制標準馬達連接板之尺寸, 請上網點選"減速機選用" 找出正確之尺寸。

★ AT065 FHM1 提供 C3 ≤12 option. ★ AT075 FHM1 提供 C3 ≤16 option. ★ AT075 FHM2 提供 C3 ≤15.875 option.

# AT-FH 系列

## 尺寸 (雙節, 減速比 $i=7\sim 50$ )

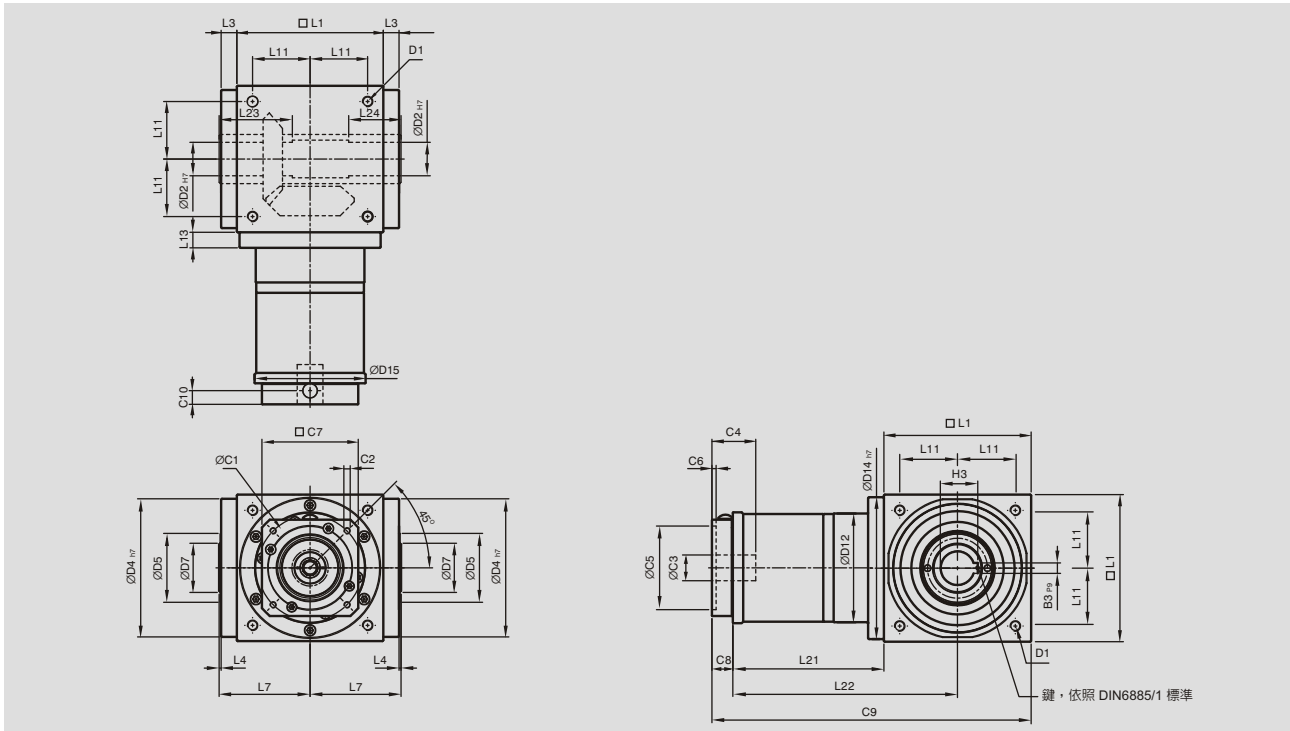

(單位: mm)

尺寸	AT065FH	AT075FH	AT090FH	AT110FH	AT140FH	AT170FH	AT210FH	AT240FH	AT280FH
D1	M4	M6	M6	M8	M10	M12	M16	M16	M16
D2 <sub>h7</sub>	13	14	18	22	32	40	50	55	60
D4 <sub>h7</sub>	63	73	88	108	135	165	205	235	275
D5	31	35	43	53	68	83	104	124	144
D7	21	22	28	33	47	55	75	85	110
D12	62	72	86	106	104	128	160	180	200
D14 <sub>h7</sub>	63	73	88	108	135	165	205	235	275
D15	62.9	72.9	87	107	106	127	158	178	198
L1	65	75	90	110	140	170	210	240	280
L3	13	14.5	15	15	15	15	20	25	25
L4	2	2	2	2	2	2	2	2	2
L7	47.5	54	62	72	87	102	127	147	167
L11	27	30	36	44	55	67	85	95	110
L13	13	15	15	15	15	15	20	25	25
L21	75	84.5	99	122	144.5	157.5	206.5	239	248
L22	107.5	122	144	177	214.5	242.5	311.5	359	388
L23	40	47	52	53	70	80	95	115	115
L24	30	32	35	35	50	55	65	80	80
C1 <sup>10</sup>	46	46	70	100	100	100	130	165	165
C2 <sup>10</sup>	M4	M4	M5	M6	M6	M6	M8	M10	M10
C3 <sup>10</sup>	≤12	≤12	≤16	≤24	≤24	≤24	≤32	≤38	≤38
C4 <sup>10</sup>	30	30	34	40	40	40	50	60	60
C5 <sup>10</sup>	30	30	50	80	80	80	110	130	130
C6 <sup>10</sup>	3.5	3.5	8	4	4	4	5	6	6
C7 <sup>10</sup>	42	42	60	92	92	92	115	142	142
C8 <sup>10</sup>	21.5	21.5	21.5	20	20	20	24	31	31
C9 <sup>10</sup>	161.5	181	210.5	252	304.5	347.5	440.5	510	559
C10 <sup>10</sup>	14.5	14.5	15.5	13	13	13	16	21	21
B3 <sub>P9</sub>	5	5	6	6	10	12	14	16	18
H3	15.3	16.3	20.8	24.8	35.3	43.3	53.8	59.3	64.4

10. C1~C10 是公制標準馬達連接板之尺寸, 請上網點選"減速機選用" 找出正確之尺寸。

# AT-FH 系列

## 尺寸 (三節, 減速比 $i=75\sim500$ )

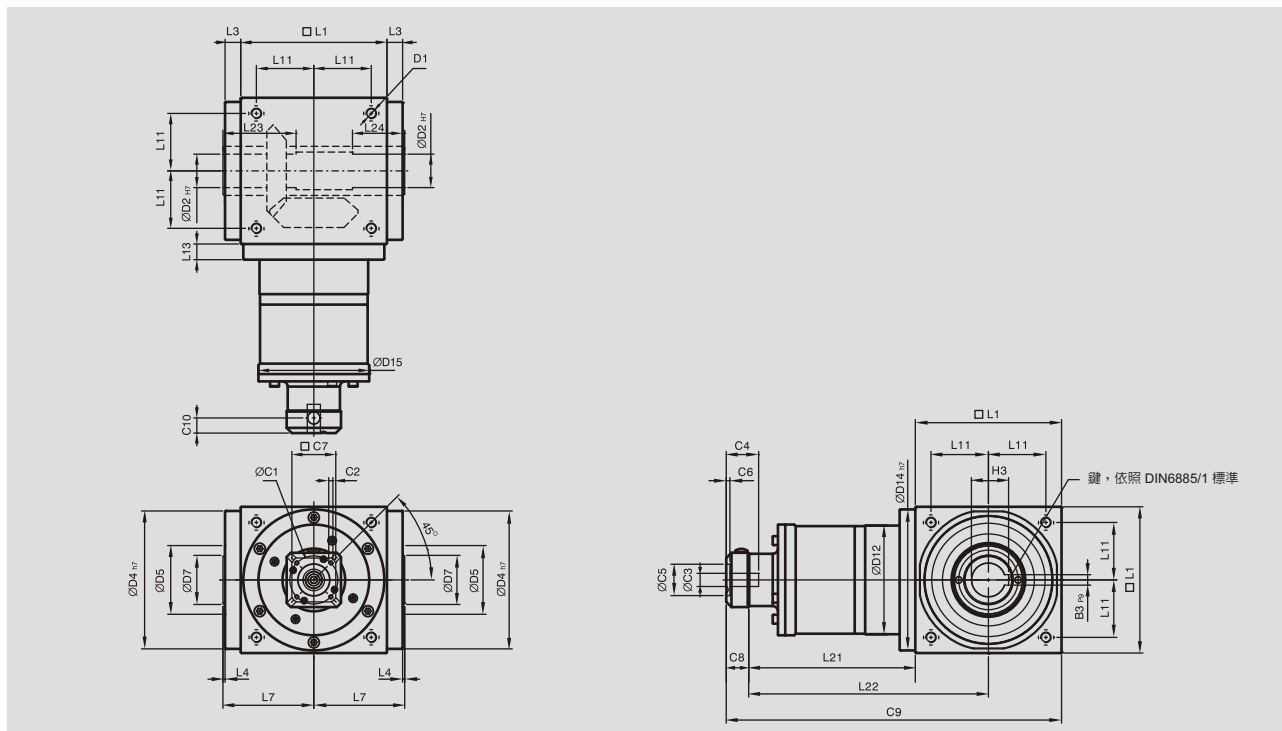

(單位: mm)

尺寸	AT110FH	AT140FH	AT170FH	AT210FH	AT240FH	AT280FH
D1	M8	M10	M12	M16	M16	M16
D2 <sub>H7</sub>	22	32	40	50	55	60
D4 <sub>H7</sub>	108	135	165	205	235	275
D5	53	68	83	104	124	144
D7	33	47	55	75	85	110
D12	106	104	128	160	180	200
D14 <sub>H7</sub>	108	135	165	205	235	275
D15	107	106	127	158	178	198
L1	110	140	170	210	240	280
L3	15	15	15	20	25	25
L4	2	2	2	2	2	2
L7	72	87	102	127	147	167
L11	44	55	67	85	95	110
L13	15	15	15	20	25	25
L21	136.5	159.5	183.5	226	269	278
L22	191.5	229.5	268.5	331	389	418
L23	53	70	80	95	115	115
L24	35	50	55	65	80	80
C1 <sup>11</sup>	46	46	70	70	100	100
C2 <sup>11</sup>	M4	M4	M5	M5	M6	M6
C3 <sup>11</sup>	≤12	≤12	≤16	≤16	≤24	≤24
C4 <sup>11</sup>	30	30	34	34	40	40
C5 <sup>11</sup>	30	30	50	50	80	80
C6 <sup>11</sup>	3.5	3.5	8	8	4	4
C7 <sup>11</sup>	42	42	60	60	92	92
C8 <sup>11</sup>	21.5	21.5	21.5	21.5	20	20
C9 <sup>11</sup>	268	321	375	457.5	529	578
C10 <sup>11</sup>	14.5	14.5	15.5	15.5	13	13
B3 <sub>P9</sub>	6	10	12	14	16	18
H3	24.8	35.3	43.3	53.8	59.3	64.4

11. C1-C10 是公制標準馬達連接板之尺寸, 請上網點選“減速機選用”找出正確之尺寸。

# AT-FC 系列

## 尺寸 (單節, 減速比 $i=1\sim5$ )

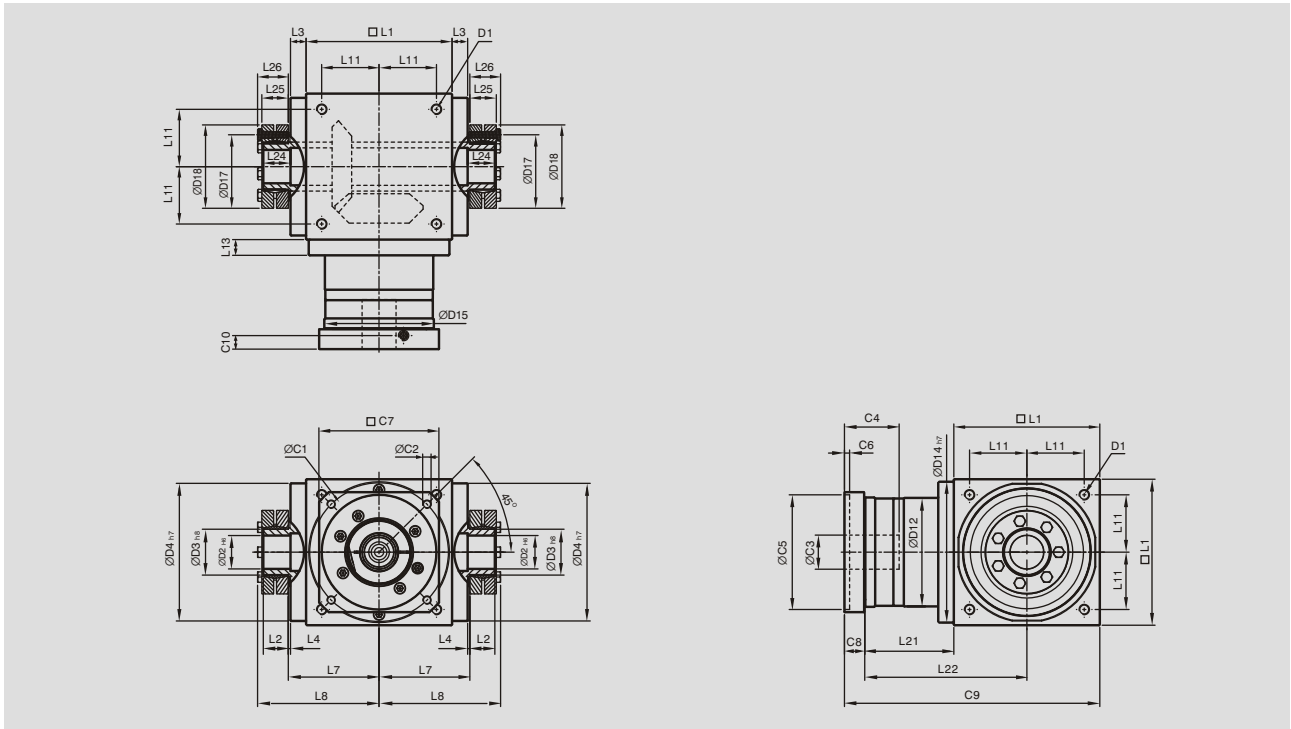

● 標準配件含 2 個縮緊盤

(單位: mm)

尺寸	AT065FC	AT075FC	AT090FC	AT110FC	AT140FC	AT170FC	AT210FC	AT240FC	AT280FC
D1	M4	M6	M6	M8	M10	M12	M16	M16	M16
D2 H6	13	14	18	22	32	40	50	55	60
D3 h8	16	16	22	25	44	50	62	68	75
D4 h7	63	73	88	108	135	165	205	235	275
D12	62	72	86	106	104	128	160	180	200
D14 h7	63	73	88	108	135	165	205	235	275
D15	62.9	72.9	87	107	105	130	158	178	198
D17	26	26	36	38	61	70	86	86	100
D18	41	41	50	50	80	90	110	115	138
L1	65	75	90	110	140	170	210	240	280
L2	14	14	18	18	24	26	29	29	30.5
L3	13	14.5	15	15	15	15	20	25	25
L4	2	2	2	2	2	2	2	2	2
L7	47.5	54	62	72	87	102	127	147	167
L8	66	72.5	85	95	116.5	113.5	161.5	181.5	205
L11	27	30	36	44	55	67	85	95	110
L13	13	15	15	15	15	15	20	25	25
L21	49	60.5	63	69.5	85.5	95	130	144.5	135
L22	81.5	98	108	124.5	155.5	180	235	264.5	275
L23	15	15	20	20	26	28	31	31	32.5
L24	15	15	20	20	26	28	31	31	32.5
L25	15	15	19.5	19.5	25.5	27.5	30.5	30.5	32.5
L26	18.5	18.5	23	23	29.5	31.5	34.5	34.5	38
C1 <sup>12</sup>	46	70	100	100	130	165	215	215	235
C2 <sup>12</sup>	M4	M5	M6	M6	M8	M10	M12	M12	M12
C3 <sup>12</sup>	★ ≤11 / ≤12	★ ≤14 / ≤15.875 / ≤16	≤19	≤24	≤32	≤38	≤42	≤48	≤55
C4 <sup>12</sup>	30	34	40	40	50	60	85	85	116
C5 <sup>12</sup>	30	50	80	80	110	130	180	180	200
C6 <sup>12</sup>	3.5	8	4	4	5	6	6	6	6
C7 <sup>12</sup>	42	60	90	90	115	142	190	190	220
C8 <sup>12</sup>	19.5	19	17	17	19.5	22.5	29	29	63
C9 <sup>12</sup>	133.5	154.5	170	196.5	245	287.5	369	413.5	478
C10 <sup>12</sup>	13.25	13.5	10.75	10.75	13	15	20.75	20.75	53.5

12. C1~C10 是公制標準馬達連接板之尺寸, 請上網點選"減速機選用" 找出正確之尺寸。

★ AT065 FCM1 提供 C3 ≤12 option. ★ AT075 FCM1 提供 C3 ≤16 option. ★ AT075 FCM2 提供 C3 ≤15.875 option.

# AT-FC 系列

## 尺寸 (雙節, 減速比 $i=7\sim 50$ )

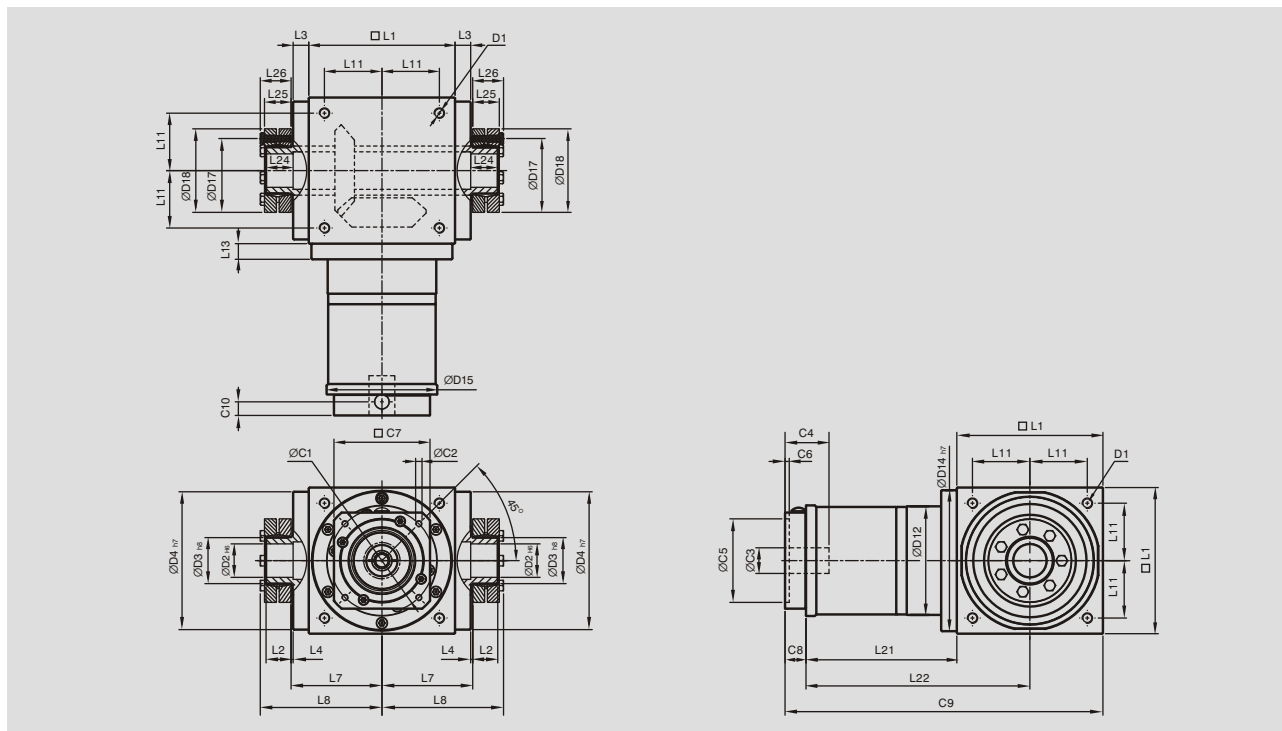

● 標準配件含 2 個縮緊盤

(單位: mm)

尺寸	AT065FC	AT075FC	AT090FC	AT110FC	AT140FC	AT170FC	AT210FC	AT240FC	AT280FC
D1	M4	M6	M6	M8	M10	M12	M16	M16	M16
D2 H6	13	14	18	22	32	40	50	55	60
D3 h8	16	16	22	25	44	50	62	68	75
D4 h7	63	73	88	108	135	165	205	235	275
D12	62	72	86	106	104	128	160	180	200
D14 h7	63	73	88	108	135	165	205	235	275
D15	62.9	72.9	87	107	106	127	158	178	198
D17	26	26	36	38	61	70	86	86	100
D18	41	41	50	50	80	90	110	115	138
L1	65	75	90	110	140	170	210	240	280
L2	14	14	18	18	24	26	29	29	30.5
L3	13	14.5	15	15	15	15	20	25	25
L4	2	2	2	2	2	2	2	2	2
L7	47.5	54	62	72	87	102	127	147	167
L8	66	72.5	85	95	116.5	133.5	161.5	181.5	205
L11	27	30	36	44	55	67	85	95	110
L13	13	15	15	15	15	15	20	25	25
L21	75	84.5	99	122	144.5	157.5	206.5	239	248
L22	107.5	122	144	177	214.5	242.5	311.5	359	388
L23	15	15	20	20	26	28	31	31	32.5
L24	15	15	20	20	26	28	31	31	32.5
L25	15	15	19.5	19.5	25.5	27.5	30.5	30.5	32.5
L26	18.5	18.5	23	23	29.5	31.5	34.5	34.5	38
C1 <sup>13</sup>	46	46	70	100	100	100	130	165	165
C2 <sup>13</sup>	M4	M4	M5	M6	M6	M6	M8	M10	M10
C3 <sup>13</sup>	≤12	≤12	≤16	≤24	≤24	≤24	≤32	≤38	≤38
C4 <sup>13</sup>	30	30	34	40	40	40	50	60	60
C5 <sup>13</sup>	30	30	50	80	80	80	110	130	130
C6 <sup>13</sup>	3.5	3.5	8	4	4	4	5	6	6
C7 <sup>13</sup>	42	42	60	92	92	92	115	142	142
C8 <sup>13</sup>	21.5	21.5	21.5	20	20	20	24	31	31
C9 <sup>13</sup>	161.5	181	210.5	252	304.5	347.5	440.5	510	559
C10 <sup>13</sup>	14.5	14.5	15.5	13	13	13	16	21	21

13. C1-C10 是公制標準馬達連接板之尺寸, 請上網點選“減速機選用”找出正確之尺寸。

# AT-FC 系列

## 尺寸 (三節, 減速比 i=75~500)

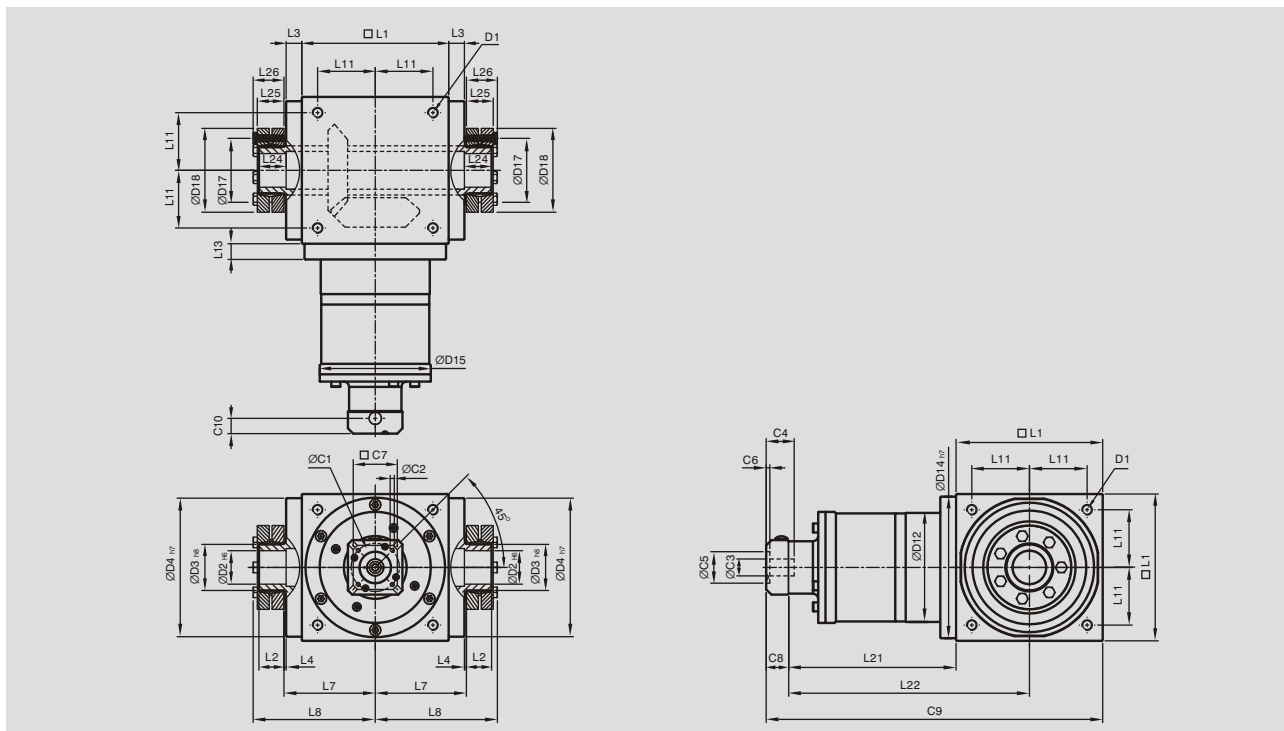

● 標準配件含 2 個縮緊盤

(單位: mm)

尺寸	AT110FC	AT140FC	AT170FC	AT210FC	AT240FC	AT280FC
D1	M8	M10	M12	M16	M16	M16
D2 H6	22	32	40	50	55	60
D3 h8	25	44	50	62	68	75
D4 h7	108	135	165	205	235	275
D12	106	104	128	160	180	200
D14 h7	108	135	165	205	235	275
D15	107	106	127	158	178	198
D17	38	61	70	86	86	100
D18	50	80	90	110	115	138
L1	110	140	170	210	240	280
L2	18	24	26	29	29	30.5
L3	15	15	15	20	25	25
L4	2	2	2	2	2	2
L7	72	87	102	127	147	167
L8	95	116.5	133.5	161.5	181.5	205
L11	44	55	67	85	95	110
L13	15	15	15	20	25	25
L21	136.5	159.5	183.5	226	269	278
L22	191.5	229.5	268.5	331	389	418
L23	20	26	28	31	31	32.5
L24	20	26	28	31	31	32.5
L25	19.5	25.5	27.5	30.5	30.5	32.5
L26	23	29.5	31.5	34.5	34.5	38
C1 <sup>14</sup>	46	46	70	70	100	100
C2 <sup>14</sup>	M4	M4	M5	M5	M6	M6
C3 <sup>14</sup>	≤12	≤12	≤16	≤16	≤24	≤24
C4 <sup>14</sup>	30	30	34	34	40	40
C5 <sup>14</sup>	30	30	50	50	80	80
C6 <sup>14</sup>	3.5	3.5	8	8	4	4
C7 <sup>14</sup>	42	42	60	60	92	92
C8 <sup>14</sup>	21.5	21.5	21.5	21.5	20	20
C9 <sup>14</sup>	268	321	375	457.5	529	578
C10 <sup>14</sup>	14.5	14.5	15.5	15.5	13	13

14. C1~C10 是公制標準馬達連接板之尺寸, 請上網點選"減速機選用" 找出正確之尺寸。

# 縮緊盤附件選配

(單位: mm)

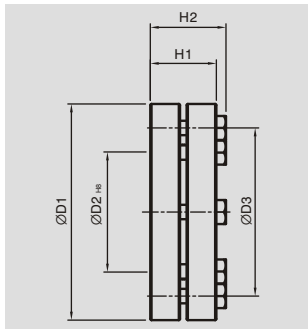

C / FC 系列	D1	D2	D3	H1	H2
SSD-d16xdw14	41	16	26	15	18.5
SSD-d22xdw18	50	22	36	19.5	23
SSD-d25xdw22	50	25	38	19.5	23
SSD-d44xdw32	80	44	61	25.5	29.5
SSD-d50xdw40	90	50	70	27.5	31.5
SSD-d62xdw50	110	62	86	30.5	34.5
SSD-d68xdw55	115	68	86	30.5	34.5
SSD-d75xdw60	138	75	100	32.5	38

## 如何選用減速機

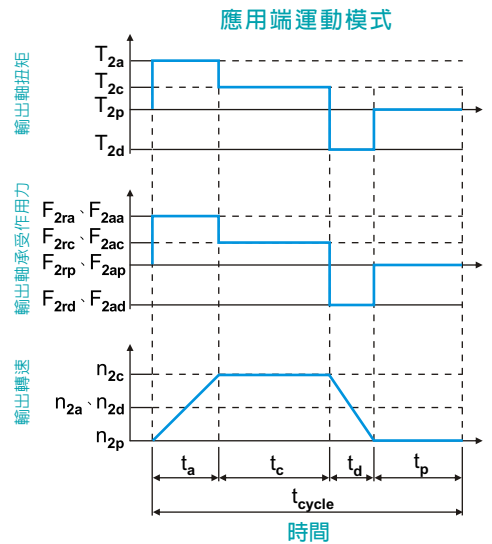
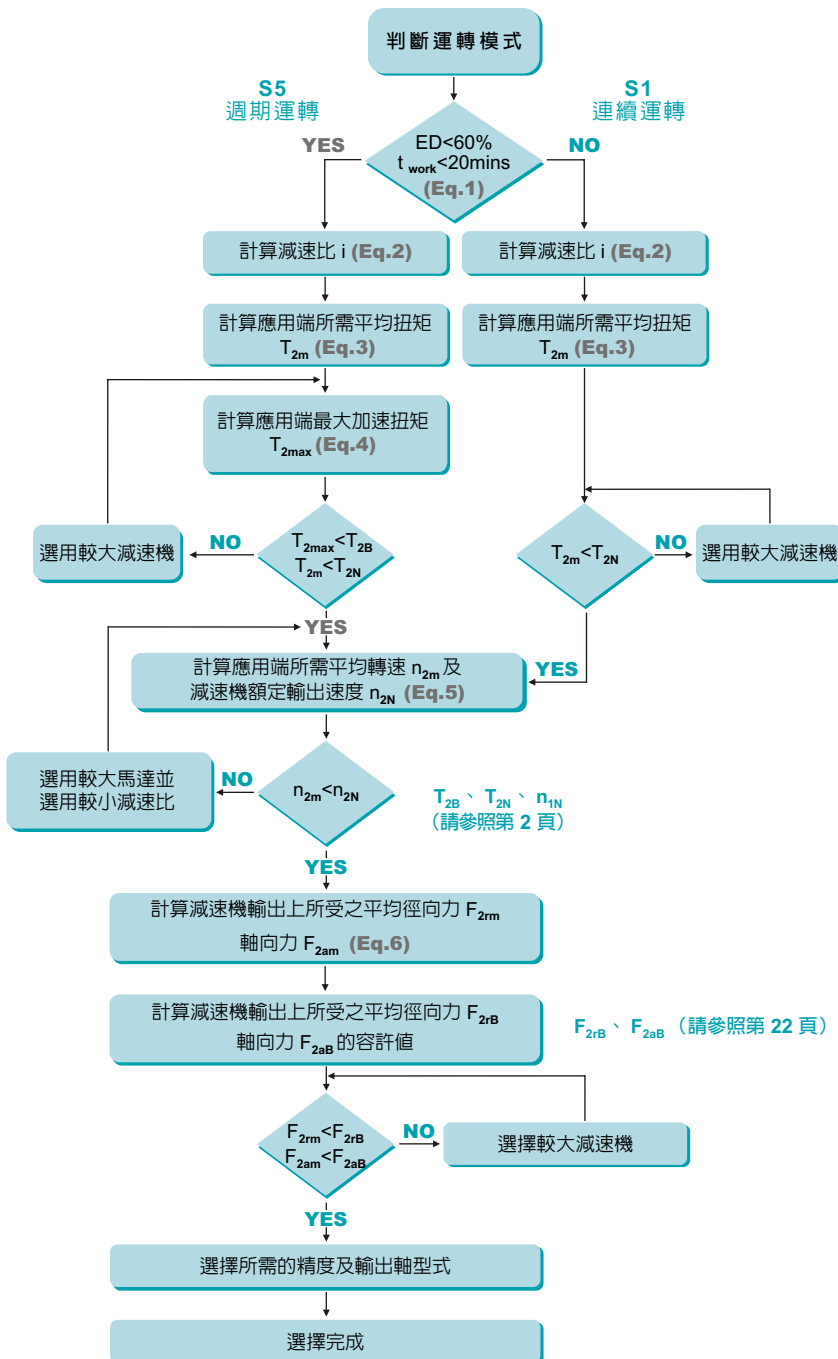

$$1. ED = \frac{t_a + t_c + t_d}{t_{cycle}} \times 100\%, t_{work} = t_a + t_c + t_d$$

下標說明: a. 加速, c. 等速, d. 減速, p. 停止 (Eq.1)

$$2. i \cong \frac{n_m}{n_{work}}$$

$n_m$  馬達輸出速度  
 $n_{work}$  實際應用速度 (Eq.2)

$$3. T_{2m} = \sqrt[3]{\frac{n_{2a}^3 \times t_a + n_{2c}^3 \times t_c + n_{2d}^3 \times t_d}{n_{2a} \times t_a + n_{2c} \times t_c + n_{2d} \times t_d}}$$

(Eq.3)

$$4. T_{2max} = T_{mB} \times i \times k_s \times \eta$$

$K_s$  負載係數

$K_s$	週期次數 / 小時
1.0	0~1,000
1.1	1,000 ~ 1,500
1.3	1,500 ~ 2,000
1.6	2,000 ~ 3,000
1.8	3,000 ~ 5,000
2.0	5,000 ~ 9,000
2.05	9,000 ~ 10,000
not recommended	above 10,000



### S5 週期運轉之建議事項

一般的應用慣量須符合以下公式：

$$\frac{J_L}{i^2} \leq 4 \times J_m$$

最適當的應用慣量須符合以下公式：

$$\frac{J_L}{i^2} \cong J_m$$

$J_L$  負載慣量

$J_m$  馬達慣量

$T_{mB}$  馬達最大輸出扭矩

$\eta$  減速機運轉效率 (Eq.4)

$$5. n_{2a} = n_{2d} = \frac{1}{2} \times n_{2c}$$

$$n_{2m} = \frac{n_{2a} \times t_a + n_{2c} \times t_c + n_{2d} \times t_d}{t_a + t_c + t_d}$$

$$n_{2N} = \frac{n_{1N}}{i} \quad (\text{Eq.5})$$

$$6. F_{2m} = \sqrt[3]{\frac{n_{2a} \times t_a \times F_{2ra}^3 + n_{2c} \times t_c \times F_{2rc}^3 + n_{2d} \times t_d \times F_{2rd}^3}{n_{2a} \times t_a + n_{2c} \times t_c + n_{2d} \times t_d}}$$

$$F_{2am} = \sqrt[3]{\frac{n_{2a} \times t_a \times F_{2aa}^3 + n_{2c} \times t_c \times F_{2ac}^3 + n_{2d} \times t_d \times F_{2ad}^3}{n_{2a} \times t_a + n_{2c} \times t_c + n_{2d} \times t_d}} \quad (\text{Eq.6})$$

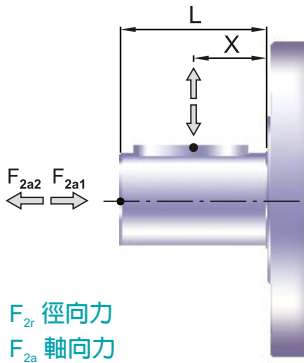

## 減速機輸出軸之容許徑向力及軸向力

減速機輸出軸所能承受之最大徑向力及軸向力，端視內部支撐軸承之設計。

台灣精銳減速機採用大尺寸的軸承及較大跨距的設計，其能承受更大的徑向及軸向負荷。

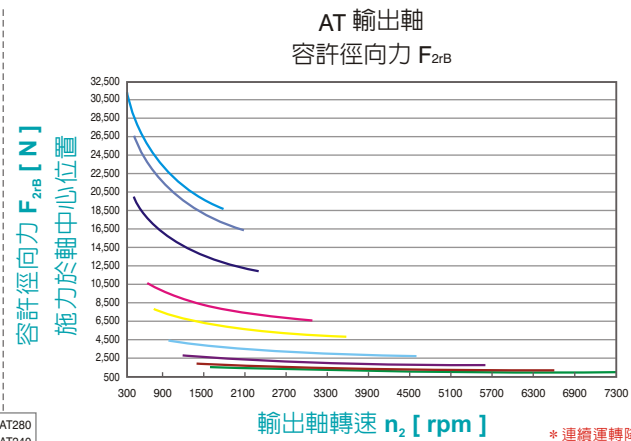
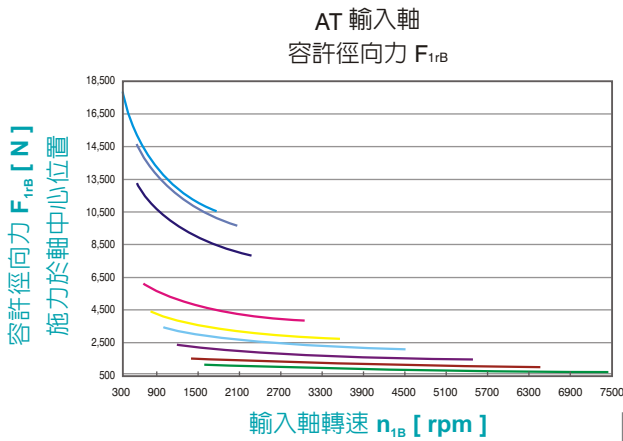

當徑向力  $F_{2r}$  施力於軸中心位置即  $X=1/2 \times L$  時，不同規格之減速機在不同輸出轉速運用下，使用壽命為 30,000 hr 時，所能承受之容許徑向力  $F_{2rB}$ ，請參照左圖。

\* 連續運轉降低使用壽命二分之一。

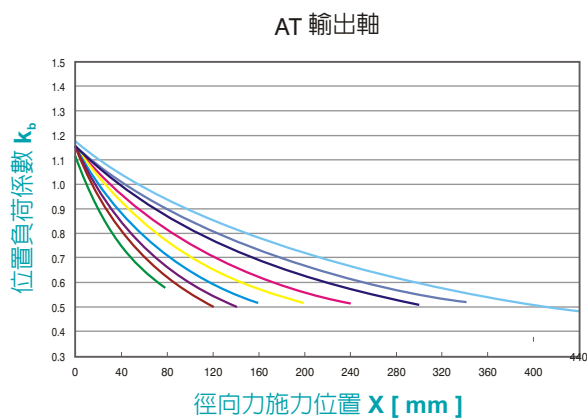
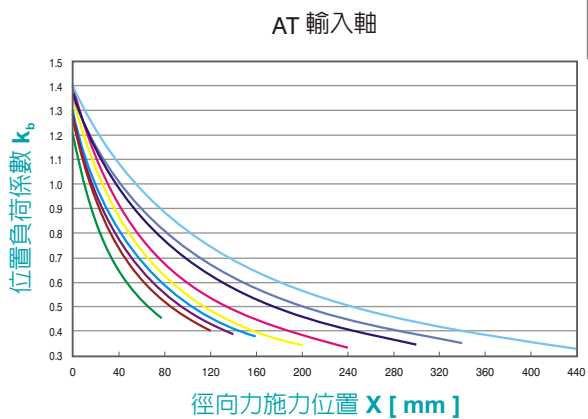

當徑向力  $F_{2r}$  施力不在軸中心位置時，越靠近減速機即  $X < 1/2 \times L$ ，所能承受之容許徑向力變大，越遠離減速機即  $X > 1/2 \times L$  時，所能承受之容許徑向力則變小，藉由左圖，依減速機規格及徑向力施力位置  $X$ ，查出位置負荷係數  $k_b$ 。

AT-L AT-H AT-C  
AT-FL AT-FH AT-FC

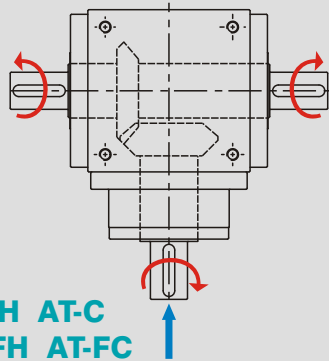

AT-4M

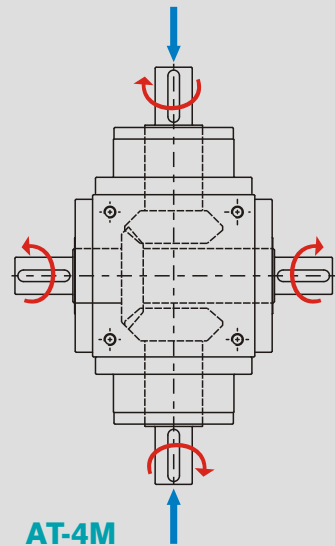

AT-L1 AT-FL1

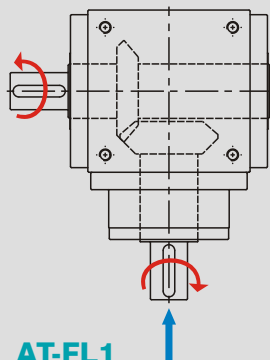

AT-LM

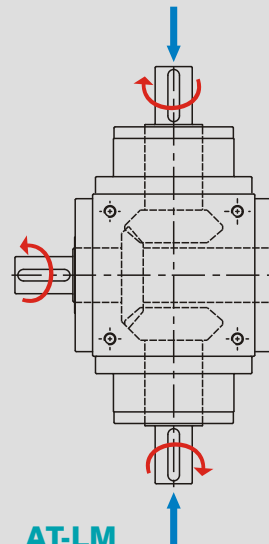

AT-R1 AT-FR1

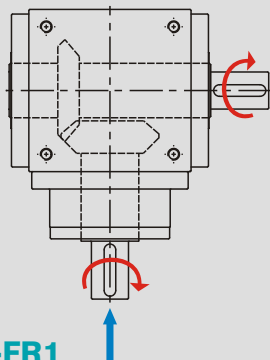

AT-RM

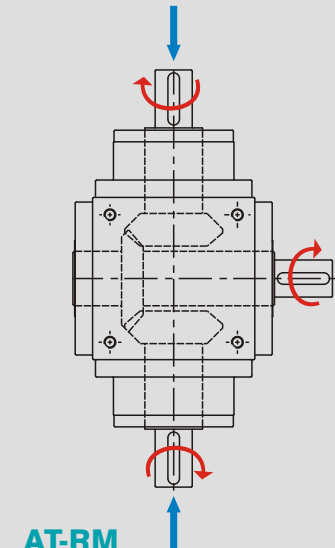

# 減速機的訂購

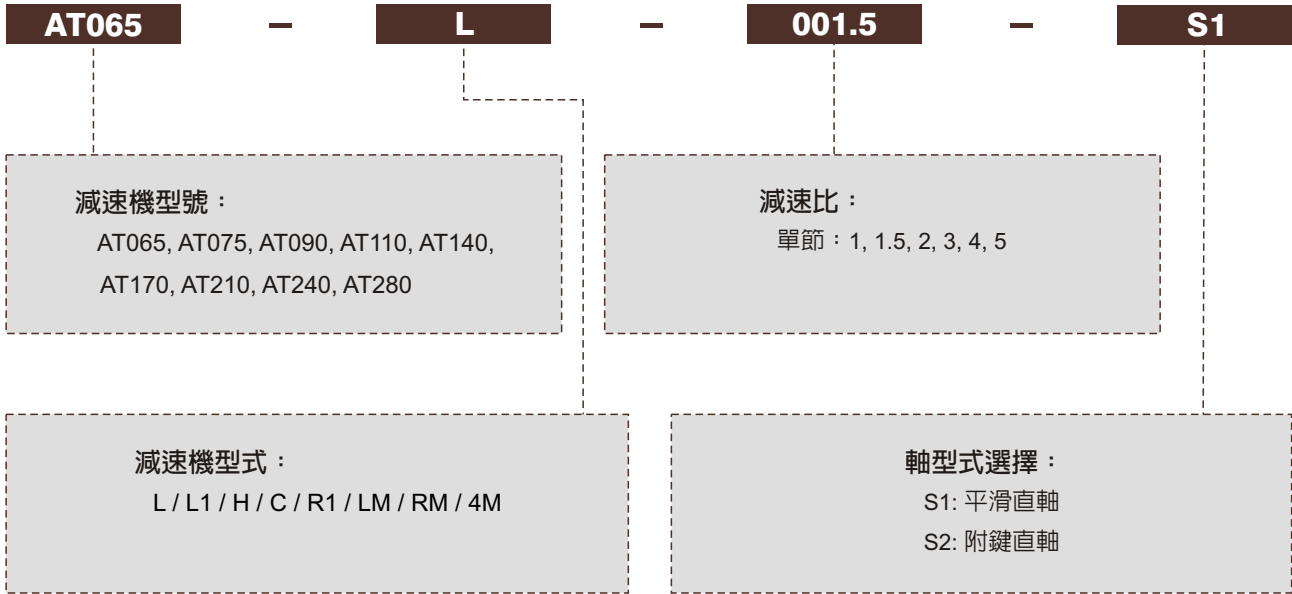

選用範例：**AT065-L-001.5-S1**

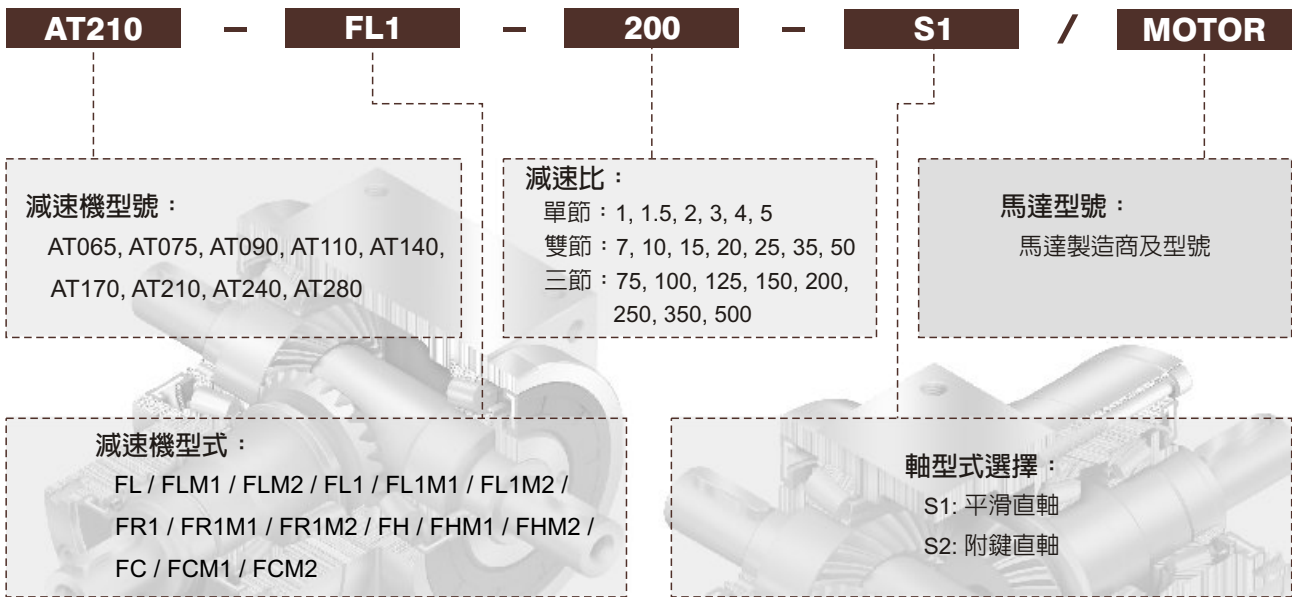

選用範例：**AT210-FL1-200-S1 / SIEMENS 1FK6 032-6AK71**

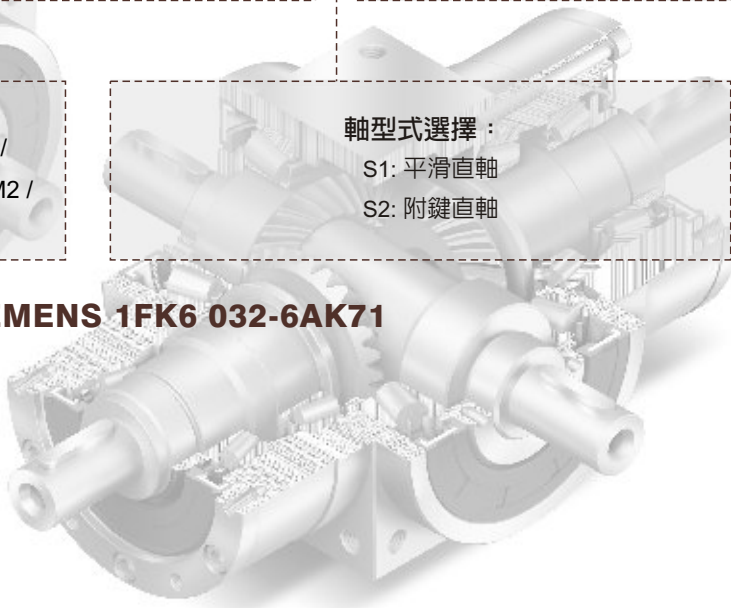

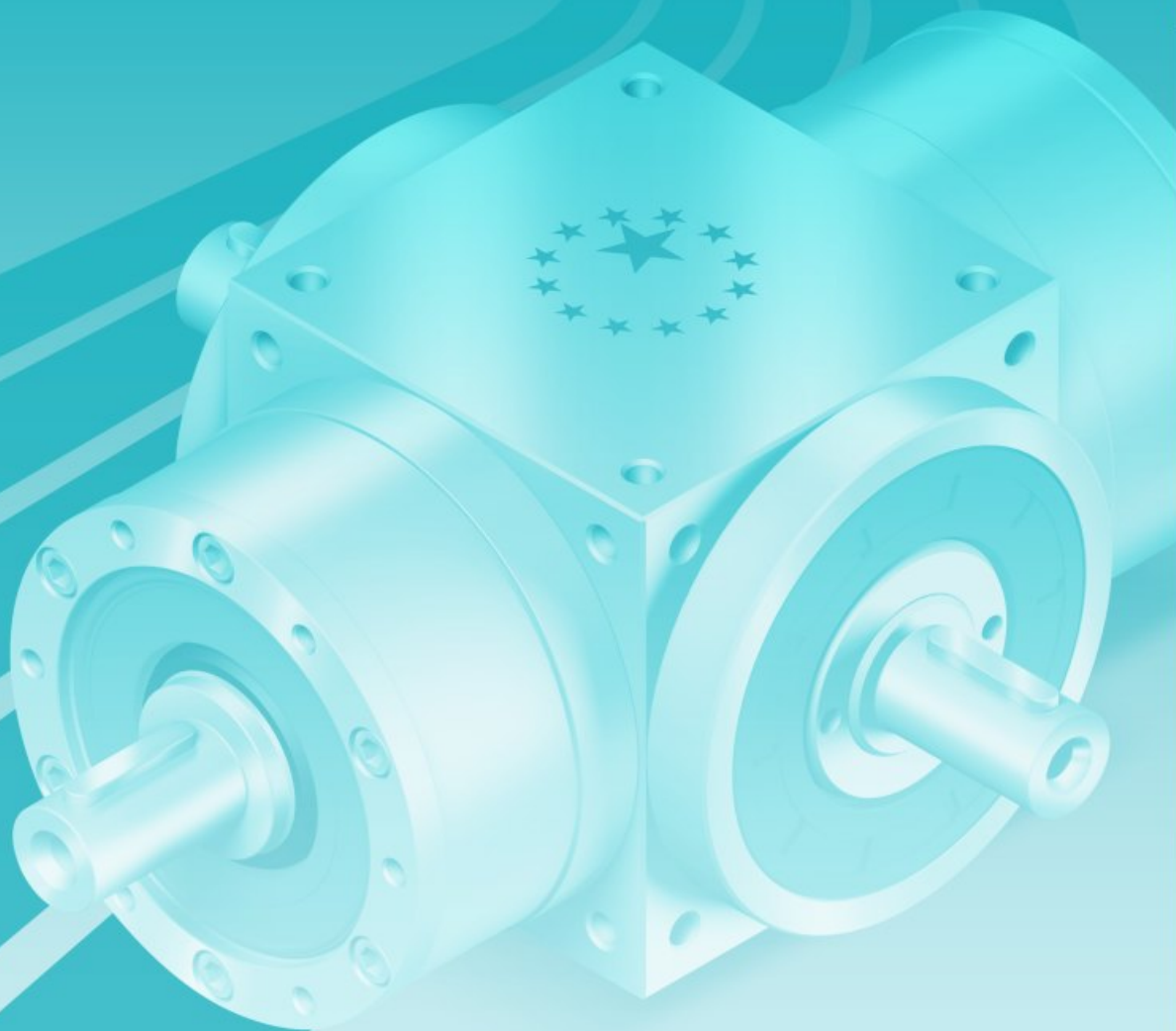

# AT SERIES

[www.apexdyna.com](http://www.apexdyna.com)



**APEX DYNAMICS, INC.**  
台灣精銳科技股份有限公司

407 台中市西屯區科園三路 10 號

電話：04-23550219 / 傳真：04-23550218

電子信箱：sales@apexdyna.com

網站：www.apexdyna.com

